

Log Cabin Quilt

Designed by Husqvarna Viking Sewing Studio, Sweden

*Appr. size of finished quilt: 112" x 92 1/2" (2.85 x 2.35 m).
(99 blocks, 9" x 9" (23 x 23 cm) in 9 rows across and 11 blocks down.)*

The Log Cabin Block is a favorite traditional quilt pattern that is easy and fast to sew. The traditional red center blocks are said to represent the fire in the fireplace or the heart of a log cabin. The fabric colors used in the blocks are frequently sewn to create a light and a dark diagonal half, as shown in the diagram. The pattern begins from the center square and strips or "logs" are stitched, right sides together around the center square. (Always sew the next strip on the side with the seam of the previous strip.)



Sewing Supplies

Light and dark cotton quilt fabrics, 44"/45" (110/114 cm) wide:

- Fabric A: 1/4 yd. (20 cm) for center blocks
- Fabric A: 1 yd. (90 cm) for inner border
- Fabric B: 5/8 yd. (50 cm) for log 2, 3
- Fabric C: 7/8 yd. (70 cm) for log 4, 5
- Fabric D: 1 yd. (90 cm) for log 6, 7
- Fabric E: 1 1/4 yd. (1.10 m) for log 8, 9
- Fabric F: 1 2/3 yd. (1 1/20 m) for log 10, 11
- Fabric G: 1 2/3 yd. (1 1/20 m) for log 12, 13
- Fabric G: 2 1/2 yd. (2.20 m) for outer border
- Fabric G: 1 yd. (80 cm) for binding
- Fabric H: 2 1/2 yd. (2.20 m.) for log 14, 15
- Fabric I: 2 1/2 yd. (2.20 m.) for log 16, 17
- Backing: 9 1/2 yds. cotton fabric
- Batting: 112" x 92 1/2" (2.85 x 2.35 m)
- Neutral colored Sewing thread
- Sewing thread to matching fabrics in outer logs, 14, 15 and 16, 17
- Sewing thread matching backing
- Schmetz Quilting Needles (412 40 20-01)
- Safety pins for basting the quilt
- Husqvarna Viking Ruler (412 66 17-01) or (412 66 15-01)
- Husqvarna Viking Cutting Mat (412 66 13-01)
- Olfa Ergonomic® Rotary Cutter (415 16 42-01)

1/4" (6 mm) seam allowance included in all measurements.

Wash and press all fabrics before you cut and sew.

1/4" (6 mm) seam allowance included in all measurements.
Wash and press all fabrics before you cut and sew.

CUT

Cut all fabrics for logs and center squares into 1 1/2" (4 cm) wide strips across fabric width.

Cut the strips from fabric A into 99 center squares, 1 1/2" x 1 1/2" (4 x 4 cm).

Cut 12 strips, 2 1/2" (7 cm) wide in fabric A for inner border.

Cut 12 strips, 7" (18 cm) wide in fabric G for outer border.

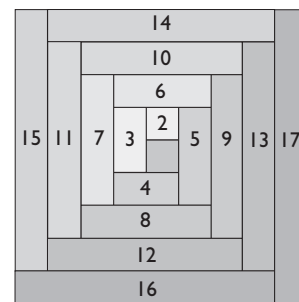

Diagram

MAKING THE BLOCKS

Select Woven Light on the Sewing Advisor. Snap on presser foot A and insert Stitch d-Card E1 with quilt and appliqué stitches in your Quilt Designer. Select stitch E1 01 for a perfect 1/4" seam allowance when the fabric edges line up with the edge of the A Foot. Adjust stitch length to 1 1/2. Thread with a light color neutral sewing thread on top and in the bobbin, that will not show through the lightest fabric in the quilt.

With right sides together and raw edges aligned, place center squares on top of the first fabric strip for log 2. Stitch the center squares to the strip, right sides together. Unfold and press seam allowance towards the center square. Illustration A.

Using rotary cutter and ruler, align ruler with the raw edge of the square and cut strips even with the edges of the center square. Repeat for all squares.

Place the two-square units on top of the fabric strip for log 3 right sides together. Sew. Align ruler with raw edge of the unit and cut to form three-piece units. Repeat for all blocks. Always press seam allowance towards the center of the block. Illustration B.

Continue sewing logs in this way until you have used all strips and have 99 finished blocks, keeping the light colored fabrics on one side and the dark on the other as illustrated. Illustration C, D, E.

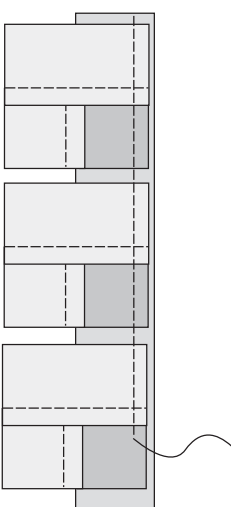

Illustration C.

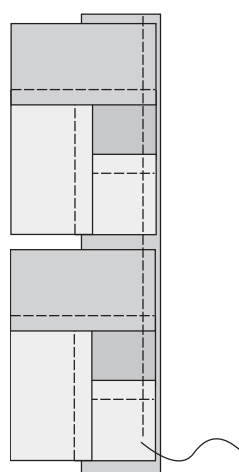

Illustration D.

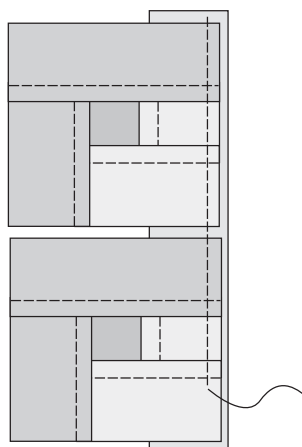

Illustration E.

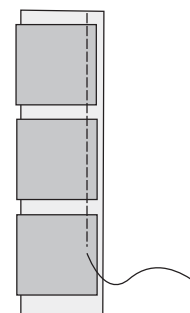

Illustration A.

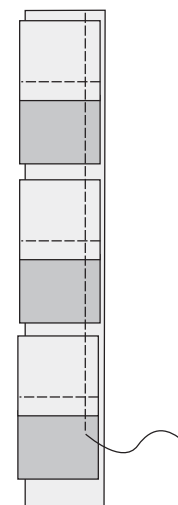

Illustration B.

COMBINING THE BLOCKS

Check up that all 99 quilt blocks are the same size. Arrange the blocks so the light and dark creates the Straight Furrow Quilt Top as illustrated. Join the blocks, right sides together, to 9 horizontal rows with 11 blocks in each row. Press seam allowance flat open.

Sew the rows to form the quilt top. Press seam allowances open.

Illustration F.

Measure width and length of the quilt top to determine the length of the borders.

INNER BORDER

Piece together on the diagonal, 1 strip for each side of the quilt top for inner border. To piece on the diagonal, place them right sides together on a 90 degree angle and stitch on a diagonal to eliminate bulk at the seams. Press seam allowance open and cut away excess seam allowance. Two strips need to measure at least the length of the quilt plus 8" (20 cm), and two needs to measure at least the width of the quilt plus 8" (20 cm).

Stitch a strip to all four sides of the quilt top, right sides together, leaving 4" (10 cm) of each strip, at all four corners, extending from the quilt top corners. Press seam allowances towards the quilt top.

Miter the border corners by folding the excess strips to the wrong side and finger press a diagonal fold mark. Stitch in the fold mark from the wrong side starting from the outer edge to the inner corner. Cut away excess seam allowance and press open. Illustration G, H.

OUTER BORDER

Sew the outer border in the same way as the inner border but start stitching 8" (20 cm) from the edge of the strip this time. Two strips need to measure at least the length of the quilt plus 16" (40 cm), and two needs to measure at least the width of the quilt plus 16" (40 cm).

QUILTING

Piece the backing to form one piece at least the size of your quilt. Place the backing on a flat surface, wrong side up. Place the batting and the quilt top on top right side up. Safety-pin baste the layers together with two safety pins in every block.

Use presser foot A or the optional Open Toe Foot for better visibility. Select stitch A1 02 on Stitch d-Card A1. Thread the machine with sewing thread matching the darker outer logs of the blocks on top, and sewing thread matching the backing in the bobbin. Quilt through all layers following the individual log cabin blocks as illustrated. The Sensor System feeds the layers evenly. Touch Needle Stop Down to pivot at the corners with the needle in the fabric. The Sensor System actually "senses" the exact pivot height for the presser foot.

After finishing the pattern of the light logs, rethread with sewing thread matching the lighter logs and continue to in the same way to quilt along the edge of the light logs. Illustration I.

Quilt through all layers around the quilt top and around the inner frame.

Remove the safety pins. Trim all raw edges even.

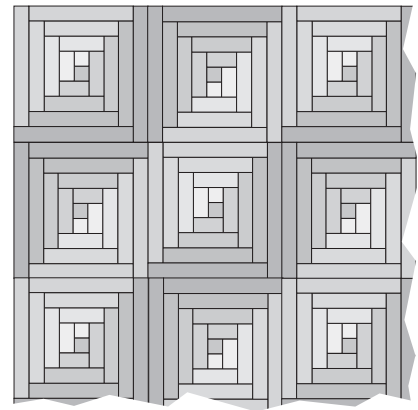

Illustration F.

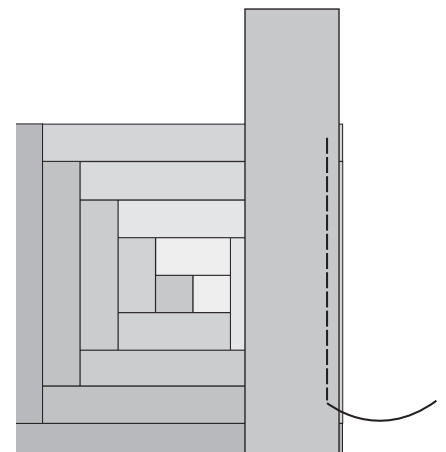

Illustration G.

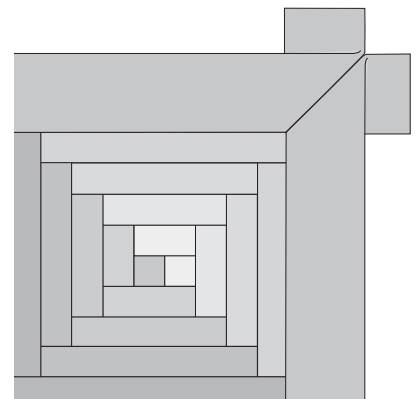

Illustration H.

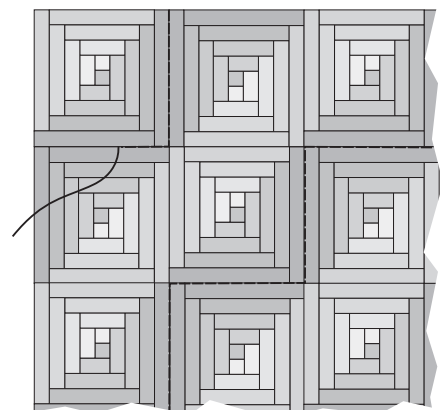

Illustration I.

BINDING

Rethread the machine with sewing thread matching the binding fabric on top and bobbin.

Cut 2 3/4" (6 cm) wide strips in fabric G, and sew them together, to go all the way around the quilt. (You will need about 425" (10 m and 60 cm). Sew the binding strips together with diagonal seam as before to reduce the bulk in the seam allowance, by placing two strips right sides together, at a 90-degree angle and stitching on the diagonal. Illustration J.

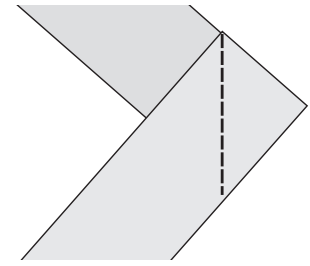

Illustration J.

Trim the seam allowances to 3/8" (1 cm) and press open. Illustration K.

Sew the remaining strips in the same way. Fold in half lengthwise, wrong sides together, and press.

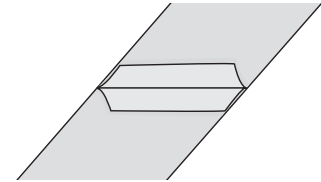

Illustration K.

Starting at the bottom edge of the quilt, lay a binding strip on the wrong side of your quilt, raw edges aligned. Touch needle stop down. Start stitching 2" (5 cm) in from the beginning of the binding and stop when you get to 1/4" (6 mm) from the first corner. When the needle stops down, the Sensor Foot Pivot automatically raises the presser foot sensing the exact pivot height for your fabric layers. Pivot towards the corner, and stitch diagonally off the corner. Illustration L.

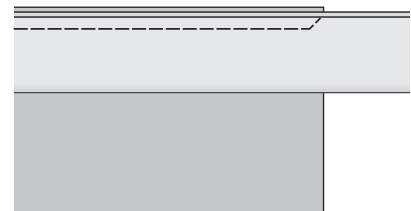

Illustration L.

Fold the binding across the diagonally stitched line and back on itself along the right side. Illustration M.

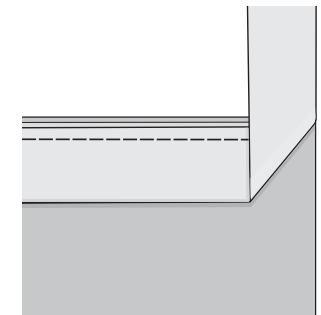

Illustration M

Start sewing again, 1/4" (6 mm) from the corner. Continue this way all the way around. Illustration N.

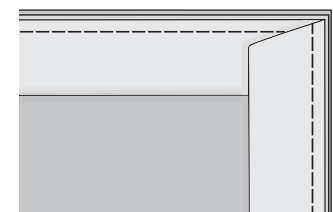

Illustration N.

To sew a mitered seam where the two pieces of binding meet, fold the ends diagonally where they meet and press. Illustration O.

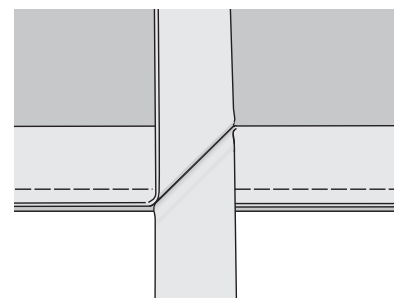

Illustration O.

Pin together along the fold lines and stitch, being careful not to catch the quilt in this seam. Trim off excess binding. Illustration P.

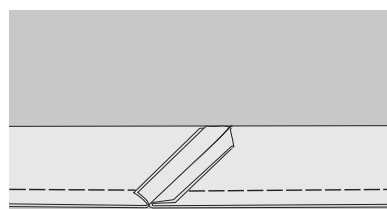

Illustration P

Turn the binding to the right side and pin in place. Tuck excess fabric at the corners into a miter. Use presser foot A and stitch A1 02 or the optional Edge/Joining Foot and stitch A1 03 and stitch the binding in place from the right side of the quilt. Illustration Q.

To label the quilt with your name, the name of the quilt, date, and other information, use the programmable letters and numbers on Stitch d-Card O1. Use the programmable letters on your Husqvarna Viking. See programming letters and stitches in your Quilt Designer User's Guide.

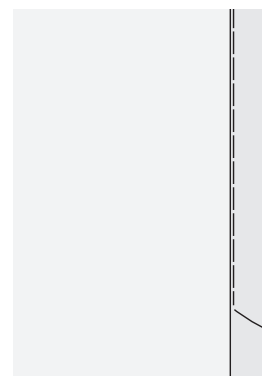

Illustration Q.



 **Husqvarna**

VIKING