

# Specialty Techniques

On your

**Huskylock**  
By Husqvarna Viking

... How and Where to Use Them

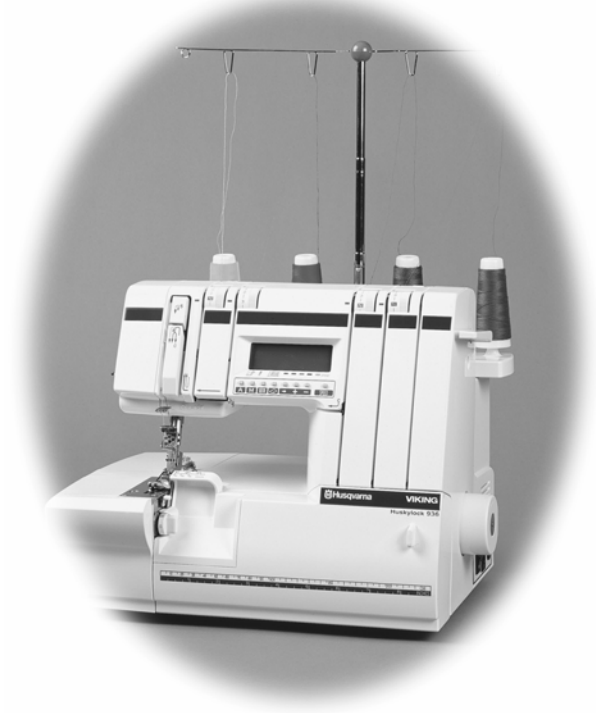

Sewing today is much easier, and much faster with your Husqvarna Viking Huskylock. All edges are “finished” on your Huskylock to prevent fraying while giving your garment a professional appearance. The cover stitches on the Huskylock 936 also give your garments a look of better ready-to-wear.

The following techniques can be used to embellish, construct or finish your projects. Experience the wonders of your Husqvarna Viking Huskylock.

Use the Sewing Advisor for set-up and tension recommendations. Some specialty techniques may require different settings. There are spaces for you to write in the settings of each technique which you find work best for your fabric and thread.

You may want to store your settings into the memory of your Huskylock for future use. Make notes on the technique page of the memory in which you stored your settings.

The optional Huskylock Accessory Feet instructions are included for your convenience. Included are the bias tape folder, bias tape binder, hemming foot, piping and cording foot and cord guide for cover stitch. Purchase the optional Huskylock Accessory Feet from your local Husqvarna Viking retailer to make serging techniques faster and easier than ever.

The following abbreviations for the needles and loopers are used:

**LN** – Left Needle

**RN** – Right Needle

**UL** – Upper Looper

**LL** – Lower Looper

**FN** – Front Needle

**CL** – Chain Stitch Looper

## Clipped and Serged Seams

*To best handle curved seams, like the side seams of a fitted dress or jacket, first clip the seam allowances where needed. Next, serge the seam allowance edges on each individual piece. Sew seams together on a conventional sewing machine. Then press the seams open for a flat seam with shape.*

*For a faster seam yet, clip the seam allowances where needed and serge seam. Press seam allowance to one side. This method allows shape of a garment where needed while eliminating a step.*

Huskylock Setting: **4 Thread Overlock** on your Sewing Advisor

Fabric: Woven Medium

Thread: Regular cone thread

Tension: LN: N \_\_\_\_\_  
RN: N \_\_\_\_\_  
UL: N \_\_\_\_\_  
LL: N \_\_\_\_\_

Stitch Length: 2.5 as set by Sewing Advisor

Stitch Width: N as recommended by Sewing Advisor

Presser Foot: "S"

Cut fabric in half and cut a curve. Clip  $\frac{1}{4}$ " into edge of fabric along seam allowance, about  $\frac{3}{4}$ " apart. Serge along each edge to finish. Using your Husqvarna Viking sewing machine, sew a straight stitch seam, and then press open.

Place Sample Here:

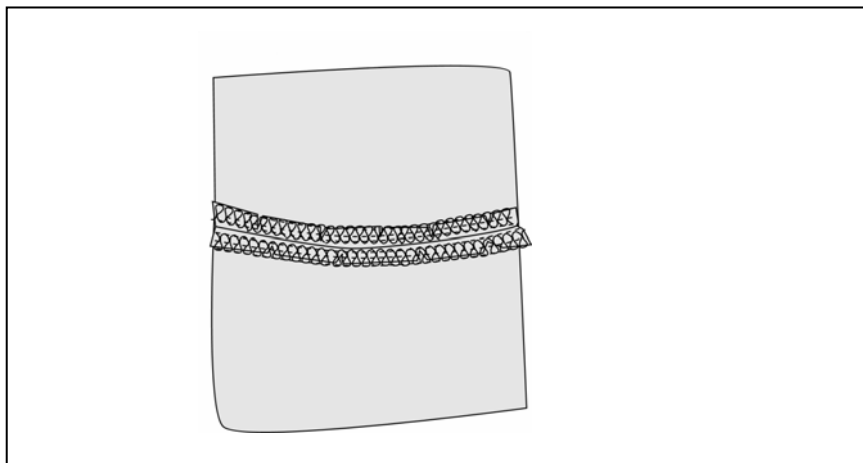

## Serger Darts

*Adopt a smart industrial sewing technique that really makes sense – serger darts. Darts are sewn to add shape to garments, but they also add bulk. Serging darts, just as you would sew them, eliminates the bulk and results in a flat seam.*

Huskylock Setting: **4 Thread Overlock** on your Sewing Advisor

Fabric: Woven Medium such as Linen or Linen-like

Thread: Regular cone thread

Tension: LN: N \_\_\_\_\_  
RN: N \_\_\_\_\_  
UL: N \_\_\_\_\_  
LL: N \_\_\_\_\_

Stitch Length: 2.5 as set by Sewing Advisor

Stitch Width: N as recommended by Sewing Advisor

Presser Foot: “S”

Mark your dart from the pattern and fold right sides together. Serge from the edge (at the widest part of the dart) to the point. When you reach the point of the dart, serge off the edge and continue serging a thread chain about 4” long. Gently pull on the tail of the thread to tie a knot at the point of the fabric.

Place Sample Here:

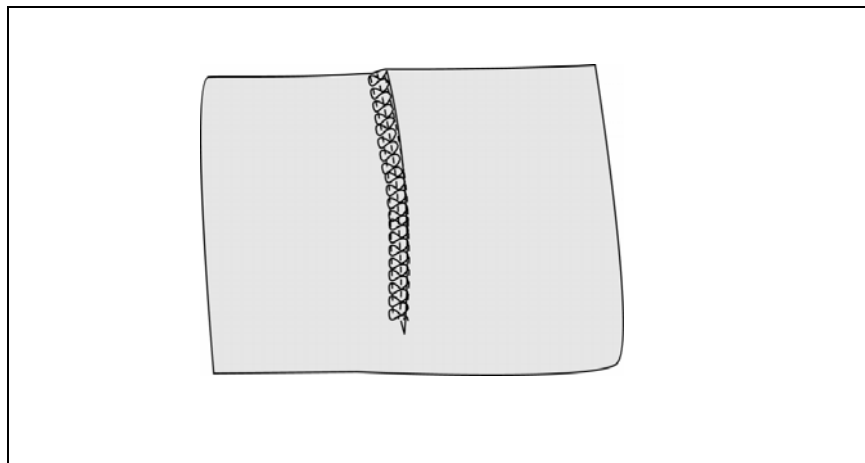

# Topstitched Ribbing

*Complete your T-shirt necklines with a professional finish using the cover stitch. Make a T-shirt in minutes using a 4-thread on your Huskylock, then put on the finishing touches just like ready to wear using the 6mm or triple cover stitch.*

Huskylock Setting: **3 or 4 thread Overlock** on your Sewing Advisor for seam

**Cover Stitch Wide** for finish

Fabric: Knit Medium (Sweatshirt fleece or T-shirt knit)  
Ribbing

Thread: Regular cone thread

Tension: 4-Thread: N – N – 3 – N as recommended by Sewing Advisor

Cover Stitch Wide:

LN: 6	_____	} as recommended by Sewing Advisor
RN: 6	_____	
CL: 3	_____	

Stitch Length: As set by Sewing Advisor

Stitch Width: As recommended by Sewing Advisor

Fold ribbing in half lengthwise, wrong sides together. Place on top of right side of neckline with cut edges even. Stretch ribbing slightly to fit neckline and serge, using 3 or 4 thread overlock stitch.

Change Huskylock to cover stitch wide or triple cover stitch.

Press seam edge toward body of garment. Top stitch on the right side of the garment, keeping needles centered over seam line.

*Hint: Use Optional Transparent Cover Stitch foot for better visibility.*

Place Sample Here:

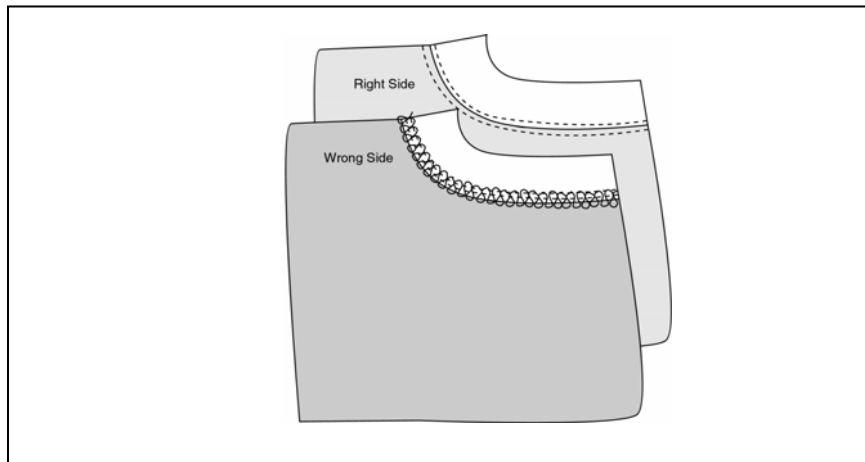

## Two Step Binding

*To achieve a professional ready-to-wear binding finish on garments, use the cover stitch to top stitch.*

Huskylock Setting: **3 or 4 Thread Overlock** on your Sewing Advisor for seam

**Cover Stitch Wide** for finish

Fabric: Woven Medium

Seam binding

Thread: Regular Cone Thread

Tension: 4 Thread as recommended by Sewing Advisor

Cover Stitch Wide as recommended by Sewing Advisor

Stitch Length: As set by Sewing Advisor

Stitch Width: As recommended by Sewing Advisor

Presser Foot: "S" for 3 or 4 Thread Overlock

"C" for Cover stitch

With right sides together, serge binding along edge of fabric, using 3 or 4 thread overlock stitch. Trim fabric as you sew.

Change Huskylock to Cover stitch wide or Triple Cover stitch.

Fold binding over seam edge to wrong side of garment. Topstitch binding from right side using edge of foot as guide along seam line.

*Hint: Use fusible thread in lower looper to hold binding in perfect position to topstitch. Press binding to wrong side of neckline.*

*Use Optional Transparent foot for better visibility.*

Place sample here:

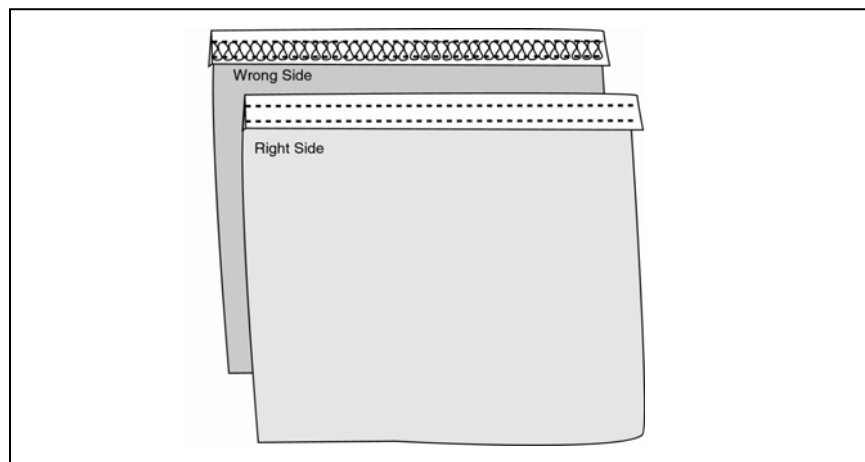

## Decorative Cord

*Serger cord can add texture and interest to a jacket, vest or any garment. Choose thread color to create tone-on-tone effect, or a contrasting color for a more dramatic detail.*

Huskylock Setting: **3 Thread Wide Overlock** on your Sewing Advisor

Fabric: Woven Medium

America Sews Tear-Away stabilizer

Yarn or decorative cording – YLI® Pearl Crown Rayon

Thread: LN: Regular cone thread  
UL: Decorative such as Sulky® 30wt. Rayon, YLI® Pearl Crown Rayon or YLI® Jean Stitch  
LL: Regular cone thread

Tension: LN: N \_\_\_\_\_  
UL: 0-1 \_\_\_\_\_ Adjust for weight of thread;  
Heavier thread = lower tension  
LL: 5-6 \_\_\_\_\_ Adjust to roll around yarn

Stitch Length: 2.5-3 \_\_\_\_\_ Adjust for weight of thread;  
Heavier thread = longer length

Stitch Width: 7 to accommodate Pearl Foot

Presser Foot: Optional Pearl Foot

Place yarn in well of pearl foot. Slide stitch finger to “R” position. Serge over yarn/cord to create decorative braid. Using the braiding foot on your Husqvarna Viking sewing machine, zigzag braid onto fabric with stabilizer underneath in design of your choice.

*Hint: Use transparent thread in Husqvarna Viking sewing machine to create the illusion of floating braid.*

Place Sample Here:

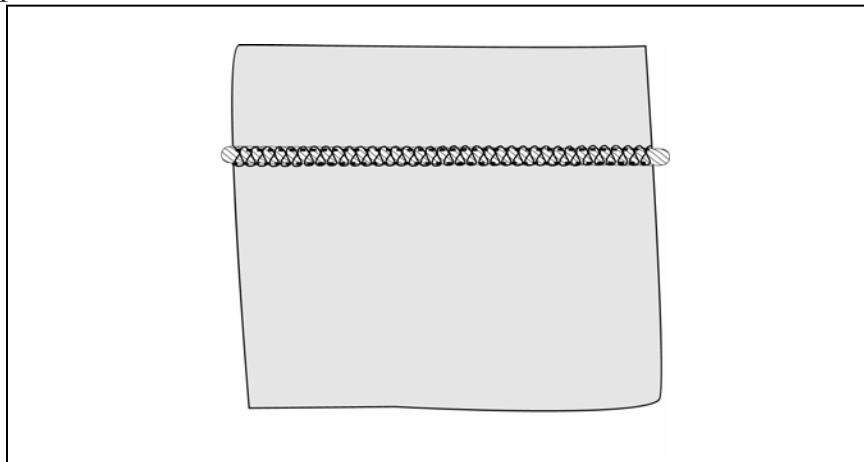

## Elastic Button Loops

*Manipulate the 3-thread overlock stitch to create elastic button loops. Serge these button loops along the edge of a dress or blouse placket for a quick and easy finish.*

Huskylock Setting: **Narrow 3-Thread Overlock** on your Sewing Advisor

Fabric: Woven Medium such as Linen or linen-like

Thread:      RN: Regular cone thread  
                 UL: Elastic thread  
                 LL: Regular cone thread

Tension:     RN: N      \_\_\_\_\_  
                 UL: 0      \_\_\_\_\_  
                 LL: N      \_\_\_\_\_

Stitch Length:      2.5-3      \_\_\_\_\_

Stitch Width: N as recommended by Sewing Advisor

Presser Foot: “S”

Serge slowly on a single layer of fabric, with right side facing up. Carefully pull extra elastic thread from Huskylock for 6” tail to allow fabric to lay flat. Then, finger press the edge of the overlock stitch toward the wrong side of the fabric. Where button loops are needed, carefully pull elastic loops from the overlock stitch to extend beyond the edge of the fabric.

Finally, edge stitch the overlock stitch with your Husqvarna Viking sewing machine to secure the elastic thread loops on the under side.

*Hint: Use the right or left needle position on your Husqvarna Viking sewing machine, while guiding the presser foot along the edge of the garment for an even edge stitch.*

Place Sample Here:

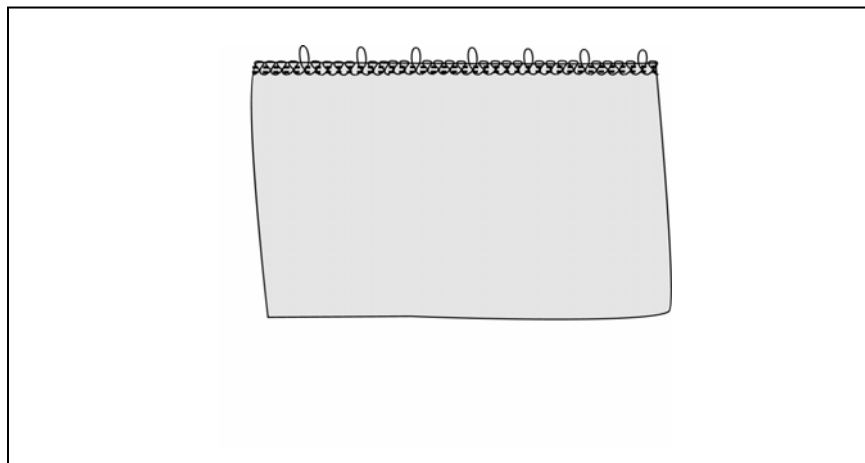

## Decorative Flatlock

*Add flatlock lines or criss-cross them to embellish wearables or home decorating projects. Use decorative threads in the upper looper for a fun, decorative look.*

Huskylock Setting: **3 Thread Flatlock** on your Sewing Advisor

Fabric: Knit Medium such as Sweatshirt Fleece

Thread:     LN:   Regular cone thread  
              UL:   Decorative thread such as YLI Jean Stitch or Pearl Crown Rayon  
              LL:   regular cone thread

Tension:    LN:   0-1     \_\_\_\_\_     Lower for heavier thread in UL  
              UL:   0-2     \_\_\_\_\_     Lower for heavier thread  
              LL:   7        \_\_\_\_\_     Adjust to balance stitch

Stitch Length:    3.0-3.5 \_\_\_\_\_     Longer length for heavier thread

Stitch Width:     7.0

Presser Foot:     Multi-Purpose (Blind Hem) Foot

Fold fabric in half with wrong sides together and serge flatlock along folded edge.

*Note: The Multi-Purpose or Blind Hem Foot will protect edge of fabric from cutter.*

If multiple rows or a pattern is desired, draw lines onto your fabric with a disappearing marking pen then fold on lines and sew. Pull fabric flat after sewing each row.

Place Sample Here:

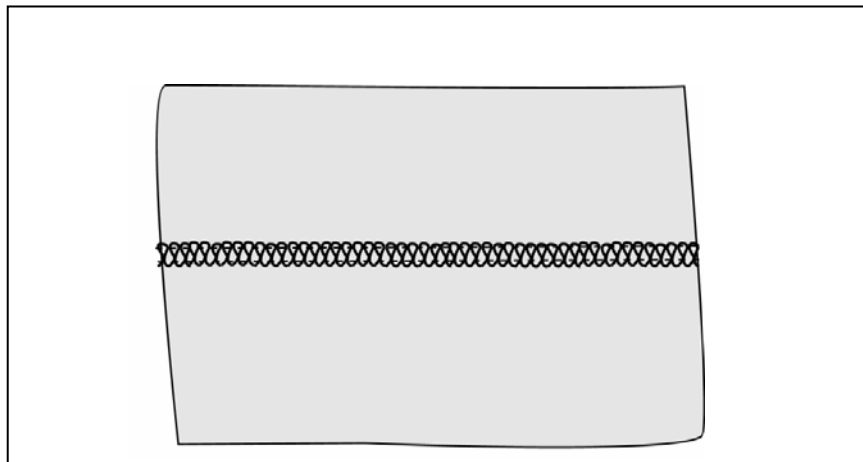

## Double Rolled Edge Piping

*Make a rich looking piping using a combination of a 4 thread setting and rolled edge setting with both needles with decorative threads. Use this technique for holiday place mats and napkins using contrasting thread or gold metallic for a rich, festive finish.*

Huskylock Setting: **3 Thread Rolled Edge** on your Sewing Advisor

Fabric: Woven Medium such as Linen or Linen-like

Thread:      LN: Regular cone thread  
                RN: Contrasting color or Metallic  
                UL: Regular cone thread or Woolly Nylon  
                LL: Regular cone thread or Woolly Nylon

Tension:     LN: N      \_\_\_\_\_  
                RN: N      \_\_\_\_\_  
                UL: 3      \_\_\_\_\_  
                LL: 6      \_\_\_\_\_ } as recommended by Sewing Advisor

Stitch Length:      1.0 as set by Sewing Advisor

Stitch Width:        6.0 as recommended by Sewing Advisor

Presser Foot: “S”

With Stitch Finger in the “R” position, serge along the edge of a single layer of fabric, cutting slightly as you sew. The rolled edge setting will allow the threads to roll slightly to the underside, while the metallic thread in the right needle will give a rich piped appearance as seen in better ready to wear.

Place Sample Here:

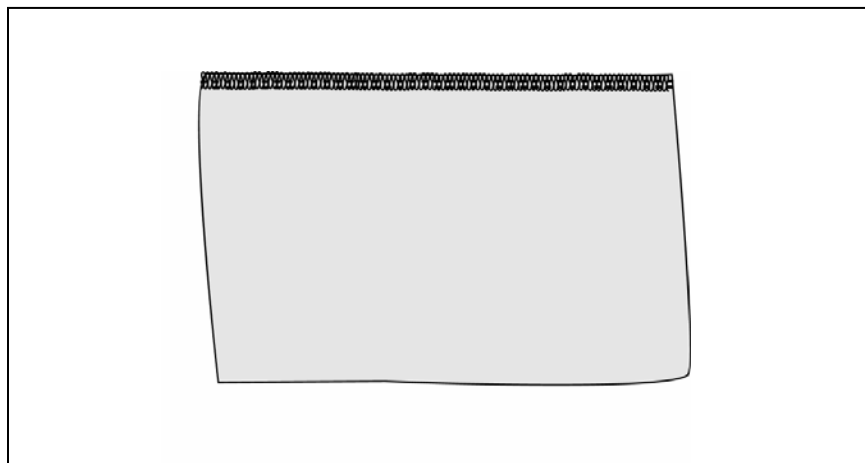

## Heirloom Lace Insertion

*Using your Huskylock, quickly insert lace on a blouse yoke or baby projects for a beautiful finish.*

Huskylock Setting: **3 Thread Rolled Edge** on your Sewing Advisor

Fabric: Woven Light such as Batiste  
Insertion Lace

Thread: RN: Regular cone thread  
UL: Wooly Nylon or Sulky® rayon  
LL: Regular cone thread

Tension: RN: 3 \_\_\_\_\_  
UL: 2-N \_\_\_\_\_ reduce for Wooly Nylon  
LL: 6 \_\_\_\_\_

Stitch Length: 1.0 as set by Sewing Advisor

Stitch Width: 6.0 as recommended by Sewing Advisor

Presser Foot: “S”

Differential Feed: 0.5-0.7 as set by Sewing Advisor

Lay insertion lace on fabric with fabric extending 1/8” to right of lace. Serge, cutting the edge of the fabric while rolling the edge of the lace to the underside of the fabric. Repeat for the other edge of lace. You can use either side of the rolled edge for the right side.

*Optional Technique: For a flatter, less bulky seam, reduce the needle tension to 0.*

Place Sample Here:

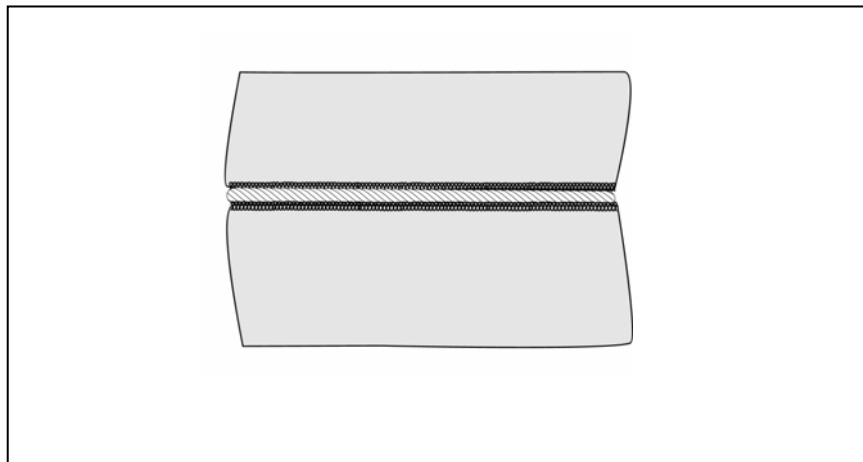

## Corded Edges

*Edge blouses, jackets, pillows and many other garments or home dec projects using the Optional Pearl Foot and 3 thread rolled edge technique.*

Huskylock Setting: **3 Thread Rolled Edge** on your Sewing Advisor

Fabric: Woven Medium to Heavy  
Medium size cording

Thread: LN: Regular cone thread (Note: use left needle to prevent sewing through cording)  
UL: Transparent thread or contrasting thread color for fabric  
LL: Regular cone thread

Tension: LN: N \_\_\_\_\_  
UL: 2-N \_\_\_\_\_ Reduce for transparent thread  
LL: 6 \_\_\_\_\_

Stitch Length: 1.0 to N \_\_\_\_\_ If invisible look is desired, lengthen  
If satin look is desired, 1.0 as set by Sewing Advisor

Stitch Width: 7.0 to accommodate Pearl Foot

Presser Foot: Optional Pearl Foot

Slide cording in channel of foot and hand turn handwheel a few times to be sure needle is not stitching through cord. This will also hold cord in place. Place folded edge of fabric under foot and sew, being careful not to cut fabric.

*Note: Edge of fabric must be finished to give finished look, such as the edge of a sleeve or placket.*

Place Sample Here:

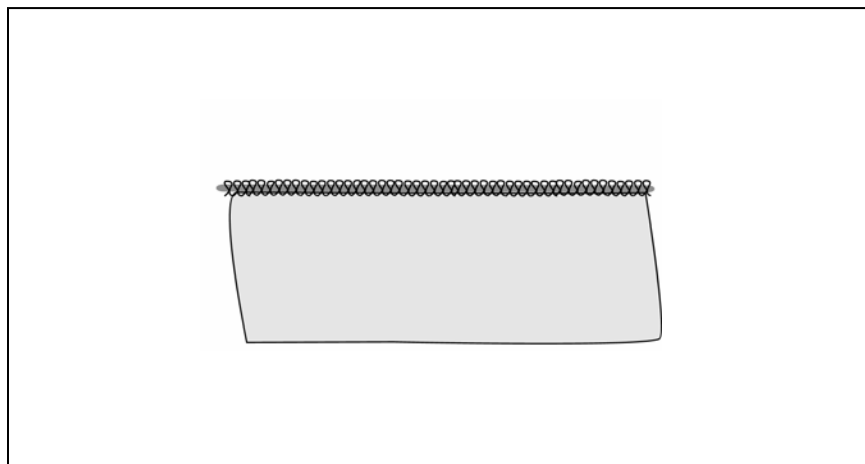

## Two Thread Flatlock Lace Application

*Finish slips or nightgowns just like ready-to-wear by adding flatlocked lace along the bottom edge. The flatlock technique ensures the lace hangs straight and eliminates bulk.*

Huskylock Setting: **2 Thread Flatlock** on your Sewing Advisor

Fabric: Knit Light such as Tricot  
1 1/2" flat lace edging

Thread: Regular cone thread

Tension: LN: 1      \_\_\_\_\_ } as set by Sewing Advisor  
          LL: 5      \_\_\_\_\_ }

Stitch Length: 3.0 as set by Sewing Advisor

Stitch Width: N as recommended by Sewing Advisor

Presser Foot: Multi-Purpose (Blindhem)

Place the straight edge of the lace right sides together with the edge of the tricot. Serge the flatlock stitch along the edge of the lace and tricot.

Pull the seam flat so the cut edges of the fabric and lace are lying flat with the lace overlapping the tricot.

*Note: You will find the 2-thread flatlock stitch sews a finer seam. It eliminates the bulk of the 3-thread flatlock.*

Place Sample Here:

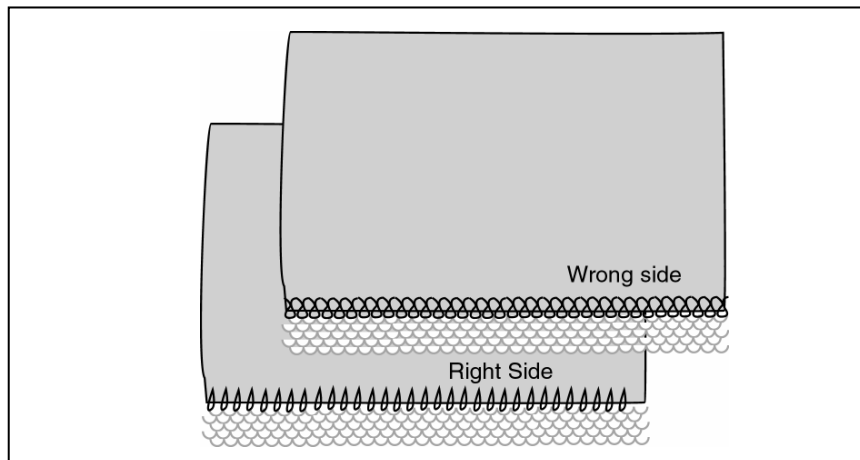

# Blanket Stitch

*Serge the finished edge of a skirt or lapel with this hand-look blanket stitch for a designer finish.*

Huskylock Setting: **2-Thread Flatlock** on your Sewing Advisor

Fabric: Woven Heavy such as Denim

2” wide strip of America Sews Clear ‘N Melt stabilizer

Thread: LN: Buttonhole Twist/YLI Jean Stitch

LL: Regular cone thread

Needle: Schmetz® Topstitching Needle size 90-100

Tension: LN: 0 \_\_\_\_\_

LL: 5-6 \_\_\_\_\_ Adjust for balanced stitch

Stitch Length: 5.0 (Longest)

Stitch Width: 7.0 (Widest)

Presser Foot: “S” or Multi-Purpose

Two Thread Converter: on Upper Looper

Remove needle thread from first thread guide. Fold fabric in half and place a 2” strip of Clear ‘N Melt on top of fabric. With balanced stitch, slowly serge along folded edge of denim, being careful not to cut fabric.

*Note: Multi-Purpose foot will protect edge of fabric from being cut as you serge.*

Remove fabric and carefully pull Clear ‘N Melt toward edge of fabric to reveal blanket stitch. The needle stitch (on underside) is being pulled to the top side of the fabric.

Place Sample Here:

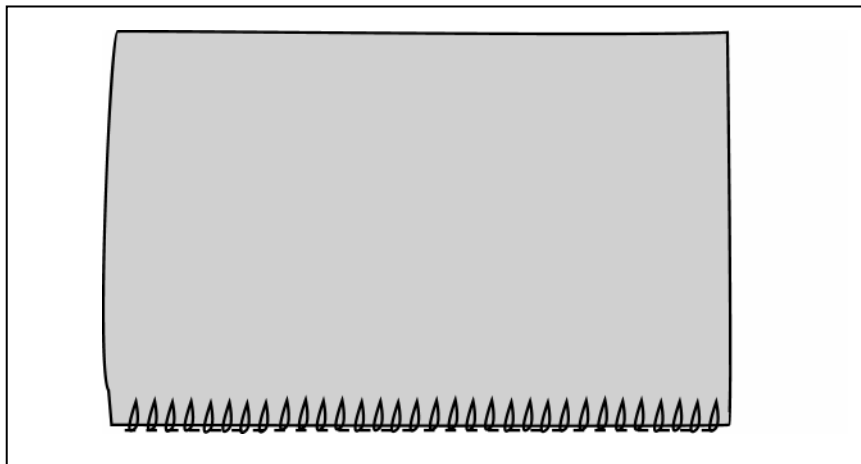

## Flat Tube Strap

*Make wide straps for camisoles, swimsuits, or sundresses. Flatlock eliminates the work of turning the tube right side out and eliminates the bulk of a seam allowance.*

Huskylock Setting: **2 Thread Flatlock** on your Sewing Advisor

Fabric: Woven Medium strip 4" x 8"

Thread: Regular cone thread

Tension: LN: 1      \_\_\_\_\_ }  
          LL: 5      \_\_\_\_\_ } As recommended by Sewing Advisor

Stitch Length: 3.0 as set by Sewing Advisor

Stitch Width: N as recommended by Sewing Advisor

Presser Foot: Multi-Purpose (Blind Hem)

Fold strip in half lengthwise with wrong sides together. Serge length of fabric along cut edges to create tube. Pull fabric flat and press with seam down center of tube.

Place Sample Here:

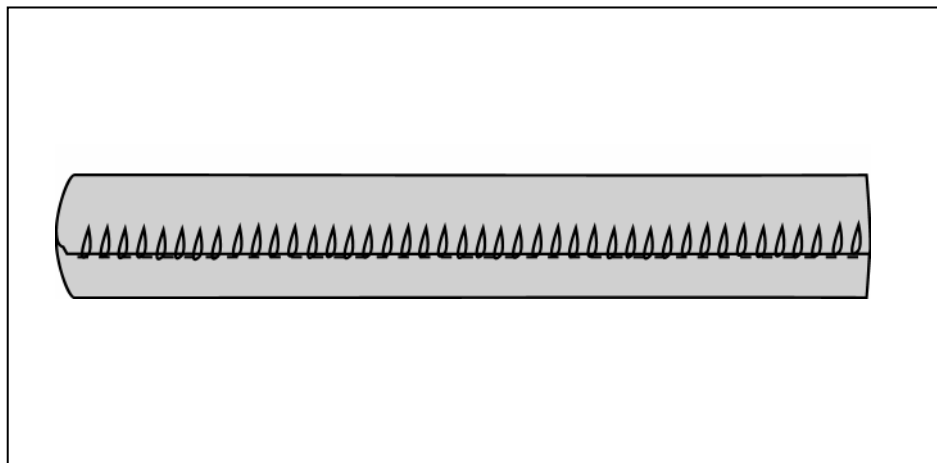

# Hand-look Quilting Stitch

*Use this technique to imitate the look of hand quilting. Use it in quilts or quilted garments for a unique finish.*

Huskylock Setting: **Chainstitch** on your Sewing Advisor  
Attach Optional Edge Guide and Holder for even rows

Fabric: Calico/batting  
Set Sewing Advisor for Woven Medium

Thread: FN: Regular cone thread  
CL: Sulky® Invisible Polyester Thread

Tension: FN: N \_\_\_\_\_  
CL: 2 \_\_\_\_\_ (Reduced for invisible thread)

Stitch length: 4 – 4.5

Stitch Width: 7.0 as recommended by Sewing Advisor

Presser Foot Pressure: Increase for thicker batting

Place 3 layers (calico/batting/calico) under presser foot and serge on wrong side.  
Sew slowly. The hand-look quilting stitch will be on the right side when you turn the fabric over.

*Note: Use either A or B needle. The Optional Transparent Cover Stitch Foot will give you more visibility when sewing your quilt.*

Place Sample Here:

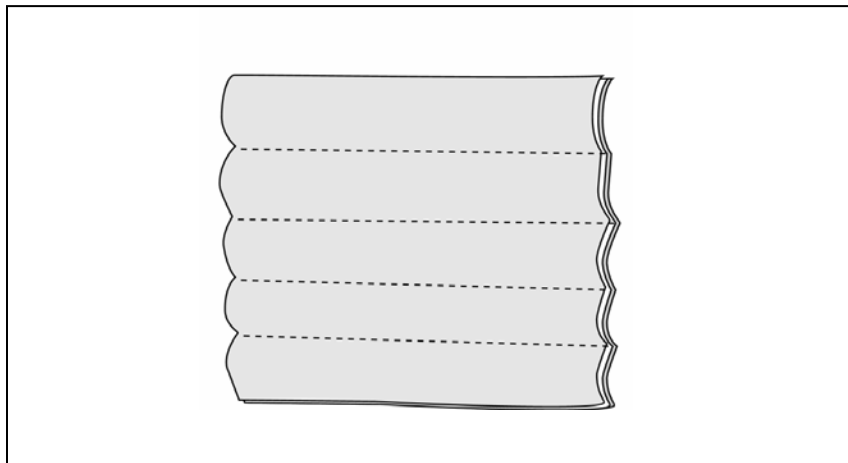

# Decorative Chainstitch Quilting

*Use the two-thread chainstitch to add a new dimension to quilted projects for fast, easy decorative quilting.*

Huskylock Setting: **Chainstitch** on your Sewing Advisor  
Attach Optional Edge Guide and Holder for even rows

Fabric: Woven Medium  
Batting

Thread: FN: Regular cone thread  
CL: Buttonhole Twist or YLI Jeans Stitch thread

Tension: FN: 5 \_\_\_\_\_  
CL: 2 \_\_\_\_\_

Stitch length: 4.0

Stitch Width: 7.0 as recommended by Sewing Advisor

Presser foot: "C"

Serge with the wrong side facing up, so chainstitch shows on the right side. Sew in rows or a meandering design. Sew slowly around curves.

*Hint: Match regular cone thread and decorative thread color for thicker looking stitch.*

Place Sample Here:

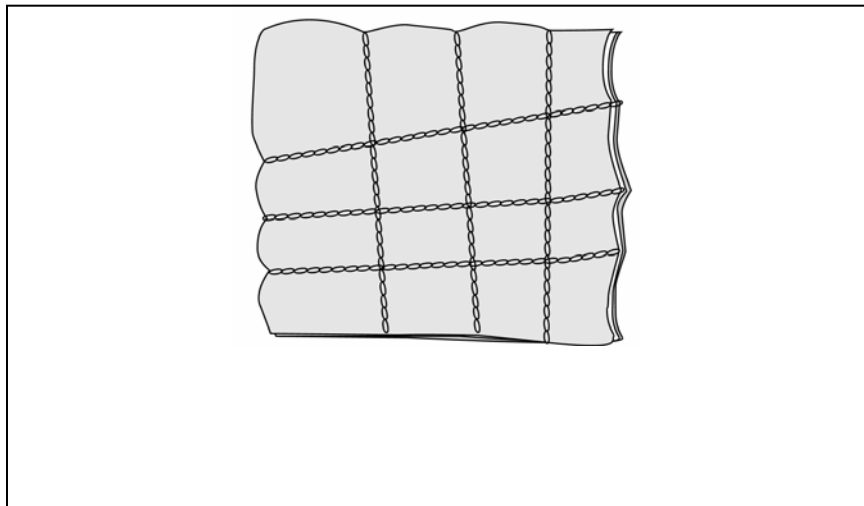

## Decorative Mock Pintucks

*These quick pintucks make a quick, yet beautiful embellishment on blouses, are perfect for heirloom sewing and fun for crafts.*

Huskylock Setting: **Chainstitch** on your Sewing Advisor  
Attach Optional Edge Guide and Holder for even rows

Fabric: Woven Light to Medium

Thread: FN: Regular cone thread  
CL: YLI® Jean Stitch, Pearl Crown Rayon or Silk buttonhole twist

Tension: LN: 5 \_\_\_\_\_  
CL: 1-2 \_\_\_\_\_ (Reduce for heavier threads)

Stitch Length: 3.0 as set by Sewing Advisor

Stitch Width: 7.0 as recommended by Sewing Advisor

Presser Foot: “C”

Using a wash away or disappearing pen, draw lines on the wrong side of the fabric where pin tucks are desired. Serge on the wrong side of your fabric, along the drawn lines, on a single layer of fabric. The chainstitch will show on the right side of the fabric to create the look of a pintuck.

*Hint: If you experience puckering in your fabric, adjust the differential feed to 0.5.*

Place Sample Here:

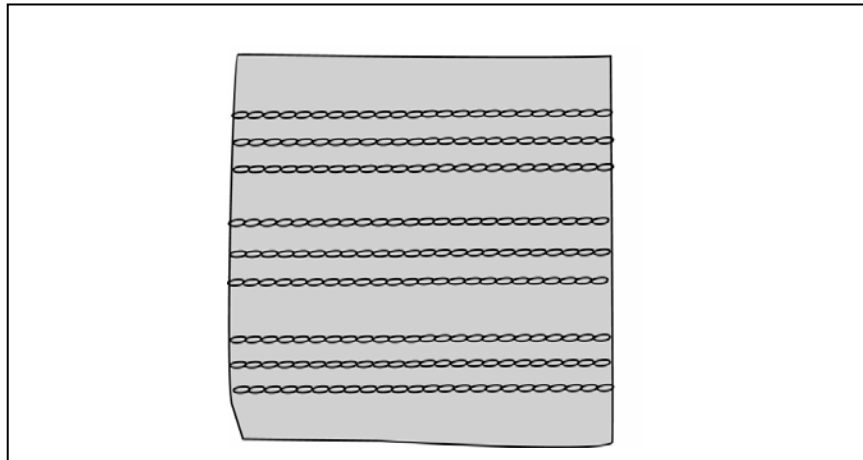

## Chainstitch Piping

*Use the chainstitch on your Huskylock, with the Optional Cover Stitch Piping Foot, for quick, perfect piping every time. Whether you create your own piping or purchase packaged piping, you will enjoy creating designer looks on your garments or home dec projects.*

Huskylock Setting: **Chainstitch** on your Sewing Advisor

Fabric: Woven Medium, 2 pieces each 3" x 6"

Thread: Regular cone thread

Tension: FN: 5 \_\_\_\_\_ Use Right Front Needle "E"  
CL: N \_\_\_\_\_

Stitch Length: 3.0 as set by Sewing Advisor

Stitch Width: 7 as recommended by Sewing Advisor

Presser Foot: Optional Cover Stitch Piping/Cording Foot

Snap on Optional Cover Stitch Piping Foot and sandwich piping between two pieces of fabric with raw edges even. Slide fabric with piping under foot, being sure piping is under groove of foot. Lower presser foot and sew seam.

*Hint: Hold piping behind foot when beginning to sew to be sure fabric and piping sew together.*

To shirr fabric, creating a heavier, decorator look to your fabric, secure one end of cording and pull other end, shirring fabric over cord. Adjust gathers in shirred piping, then place between two layers of fabric and sew as above.

Place Sample Here:

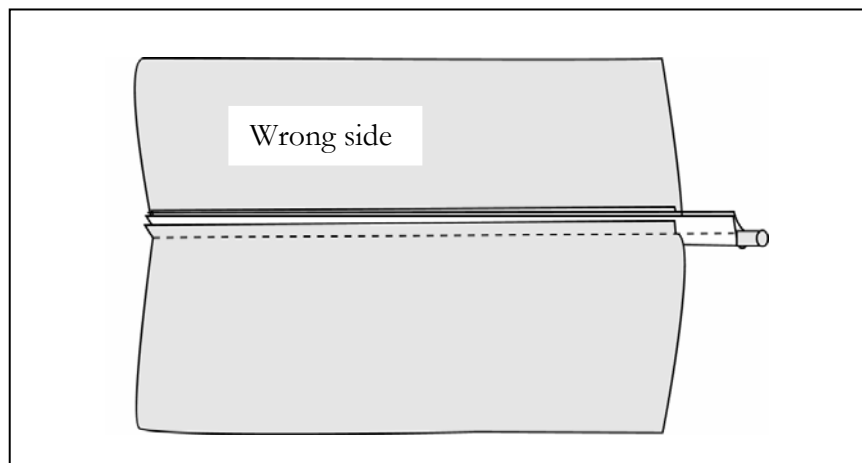

## Cover Stitch Fagoting

*Create your own lacy fabric using the cover stitch and decorative thread to serge ribbons or tubes of fabric together.*

Huskylock Setting: **Cover Stitch Wide** on your Sewing Advisor

Fabric: Ribbon or fabric tubes

Thread: LN: Regular cone thread  
RN: Regular cone thread  
CL: Decorative thread of choice-  
Lightweight thread (YLI silk thread) for lacier, more delicate look or Heavier thread (Pearl Crown Rayon) for heavier appearance

Tension: LN: 6 \_\_\_\_\_  
RN: 7 \_\_\_\_\_  
CL: 1-2 \_\_\_\_\_ (lower tension for heavier thread)

Stitch Length: 4-5 \_\_\_\_\_ (longer length for heavier thread)

Stitch Width: 7.0 as recommended by Sewing Advisor

Foot: Optional Transparent Cover Stitch Foot

Fabric prep: Lay a layer of America Sews Clear 'N Melt on ironing board and pin in place at corners to hold taut. Spray back of ribbon or fabric tubes with temporary spray adhesive. Lay ribbon or fabric tubes onto Clear 'n Melt in rows 1/4" apart.

*Hint: Take a wooden yard stick and lay on edge. Then simply butt the edges of ribbon or fabric tubes to either side of the yard stick to get a perfect 1/4".*

For more stability when stitching, apply another layer of Clear 'N Melt on top. Spray temporary spray adhesive onto "fabric" layer and Clear 'N Melt on top. The temporary spray adhesive will prevent layers from shifting. Sew 6mm cover stitch down center of 1/4" spacing. Use iron to melt stabilizer away.

Place Sample Here:

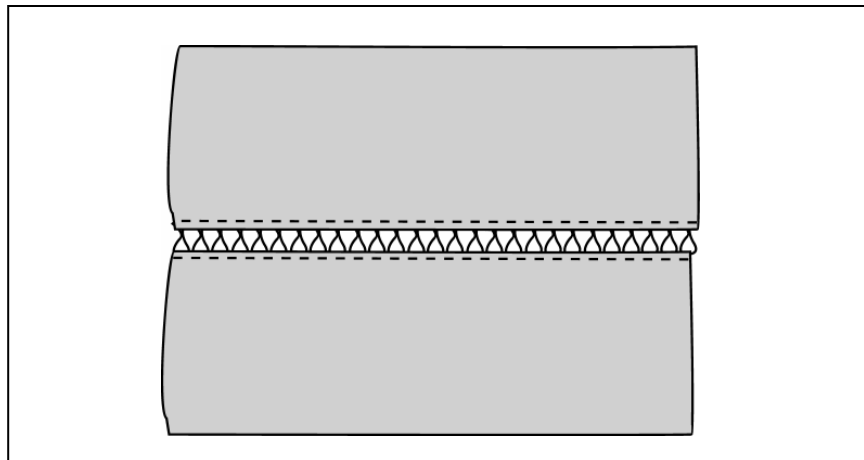

# Mock Flat Felled Seam

*Create the look of a flat felled seam in half the time with a cover stitch.*

Huskylock Setting: **Cover Stitch Wide, Narrow or Triple Cover** on your Sewing Advisor

Fabric: Woven Heavy such as Denim

Thread: Regular cone thread

Tension: LN: 6  
RN: 7  
CL: N

\_\_\_\_\_ } as recommended by Sewing Advisor  
\_\_\_\_\_ }  
\_\_\_\_\_ }

Stitch Length: 3.5 as set by Sewing Advisor

Stitch Width: 7.0 as recommended by Sewing Advisor

Foot: Optional Transparent Cover Stitch Foot

With fabric right sides together, serge  $5/8$ " seam, using the cover stitch. Fold seam allowance to one side so straight stitching is exposed and looper threads are hidden. Using the transparent cover stitch foot for better visibility, topstitch next to seam line on right side of fabric, to stitch the seam allowance flat.

Place Sample Here:

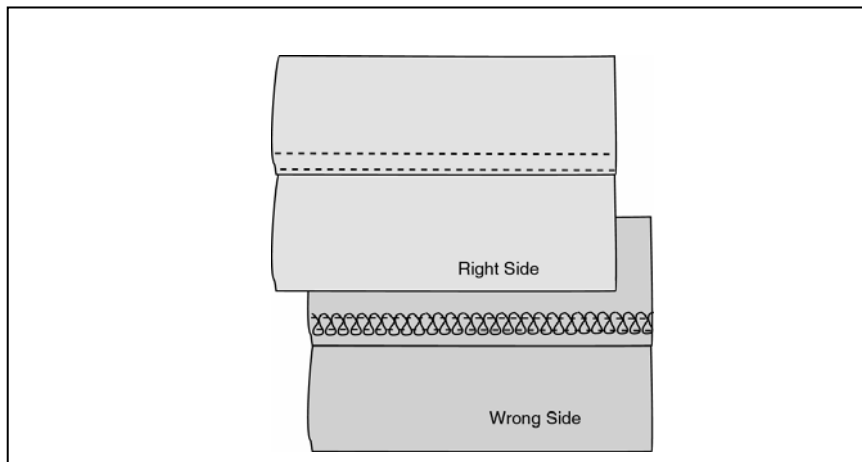

## Cover Stitch Hemming Foot

*Use the Optional Cover Stitch Hemming Foot for even hems on your garments or home dec projects. Simply press your hem allowance, then let the foot and your Huskylock do the work for you.*

Huskylock Setting: **Cover Stitch Wide** on your Sewing Advisor

Fabric: Woven or Knit Medium

Thread: Regular cone thread

Tension: LN: 6      \_\_\_\_\_  
RN: 7      \_\_\_\_\_ } as recommended by Sewing Advisor  
CL: 3      \_\_\_\_\_

Stitch Length: 3.5 as set by Sewing Advisor

Stitch Width: 7 as recommended by Sewing Advisor

Presser Foot: Optional Cover Stitch Hemming Foot

Measure and press a 1" hem along one edge of your fabric. Snap on hemming foot. Slide fabric into slot in front of foot with the turned under hem facing down. Lower presser foot and sew hem, having left needle along cut or raw edge of hem. For a designer or better ready-to-wear look, use the triple cover stitch.

The cover hem is ideal for knits and wovens, as the cut edge on the underside will be covered by the cover stitch.

Place Sample Here:

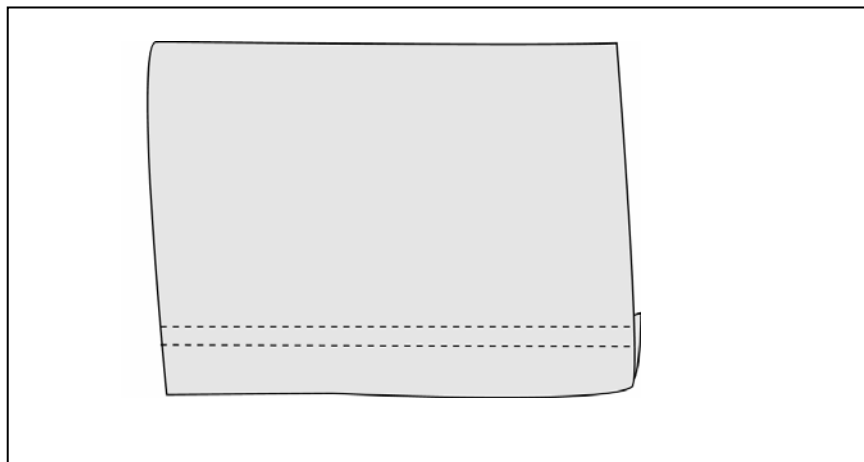

## Cover Stitch Bias Tape Folder Foot

Use the *Optional Cover Stitch Bias Tape Folder Foot* to fold and attach all in one quick, easy step. Use this foot to cover seams with bias tape or make belt loops for garments or to hang a quilt or wallhanging.

Huskylock Setting: **Cover Stitch wide** on your Sewing Advisor

Fabric: Woven Medium

1" wide strip of bias cut fabric, or pre-packaged narrow single fold

Thread: Regular cone thread

Tension: LN: 6    \_\_\_\_\_  
RN: 7    \_\_\_\_\_  
CL: 3    \_\_\_\_\_ } as recommended by Sewing Advisor

Stitch Length: 3.5 as set by Sewing Advisor

Stitch Width: 7 as recommended by Sewing Advisor

Presser Foot: *Optional Cover Stitch Bias Tape Folder Foot*

Snap on Bias Tape Folder Foot and insert tape into tape guide.

*Hint: Cut end of bias tape into point to make it easier to insert. Use your tweezers in slot on top of foot to slide bias tape into folder and up to needles.*

Lower presser foot and sew on bias tape only for an inch or two. For belt loops, continue to strip of bias tape, then cut into desired lengths for belt loops. To sew onto fabric, slide fabric under bias tape, up to needles and sew.

This foot is ideal for covering seams with decorative fabric bias strips to add a designer touch to a garment or placemats.

Attach Sample Here:

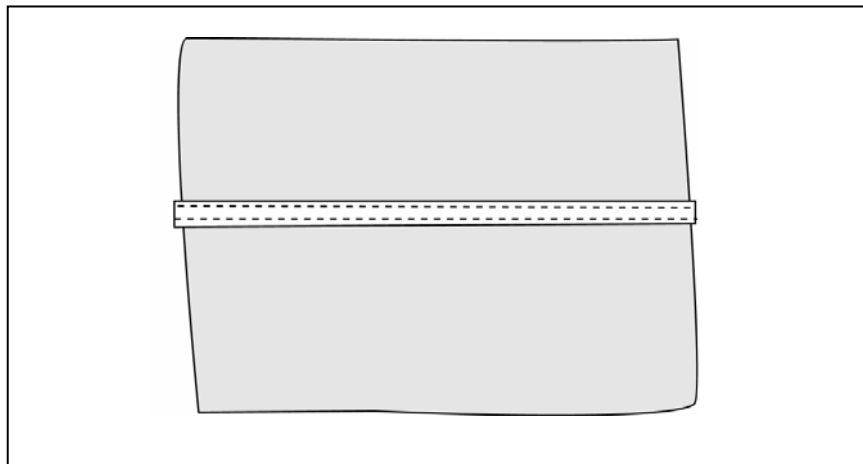

## Cover Stitch Bias Tape Binding Foot

*Use the Optional Cover Stitch Bias Tape Binding Foot to finish edges in one step with the Cover Stitch Wide or Chainstitch. Perfect for finishing the edges of garments, placemats and other home dec projects.*

Huskylock Setting: **Cover Stitch Wide** on your Sewing Advisor

Fabric: Woven Medium

Pre-folded extra wide double fold bias tape

Thread: Regular cone thread

Tension: LN: 6    \_\_\_\_\_  
RN: 7    \_\_\_\_\_  
CL: 3    \_\_\_\_\_ } as recommended by Sewing Advisor

Stitch Length: 3.5 as set by Sewing Advisor

Stitch Width: 7 as recommended by Sewing Advisor

Presser Foot: Optional Bias Tape Binding Foot

Insert the bias tape into tape guide on foot. Slide bias tape up to needles. Lower presser foot and sew into bias tape an inch or two to catch the bias tape. Raise foot and slide fabric into groove of foot to the right edge of the foot. Lower foot and sew bias tape onto edge of fabric.

If single stitch is desired instead of 6mm cover stitch, use left or center needle, depending on the desired results.

Place Sample Here:

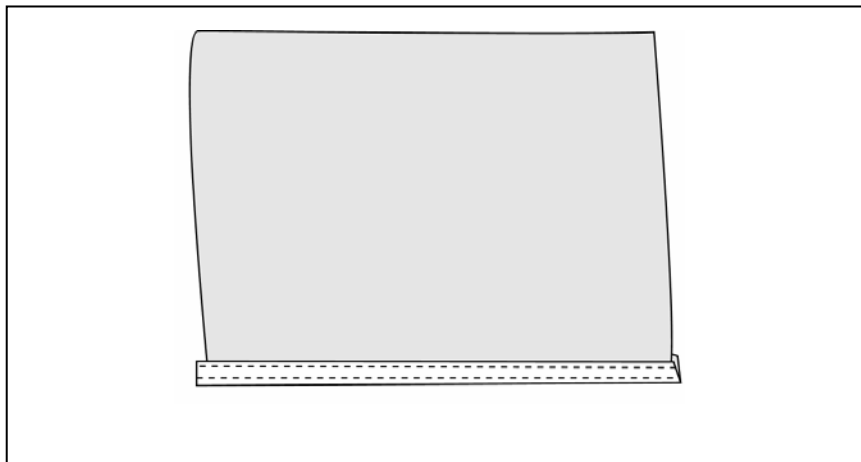

## Flat Lace Application

*Finish lingerie quickly and professionally with a cover stitch finish to prevent lace from curling along the edge of your lingerie or fine linens.*

Huskylock Setting: **Cover Stitch Wide** on your Sewing Advisor

Fabric: Woven Light, such as Batiste  
Flat Edging lace

Thread: Regular cone thread

Tension: LN: 6 \_\_\_\_\_  
RN: 6 \_\_\_\_\_  
CL: 3 \_\_\_\_\_

Stitch Length: 3.5 as set by Sewing Advisor

Stitch Width: 7.0 as recommended by Sewing Advisor

Presser Foot: Optional Flat Lace Foot

Insert fabric into the left fabric guide of foot, and the lace into right guide of the foot, with wrong side of lace facing right side of fabric. The lace will overlap the fabric approximately 1/4" along the edge. Stitch lace and fabric together. The foot keeps both fabric and lace straight for perfect edges on lingerie or fine linens.

Place Sample Here:

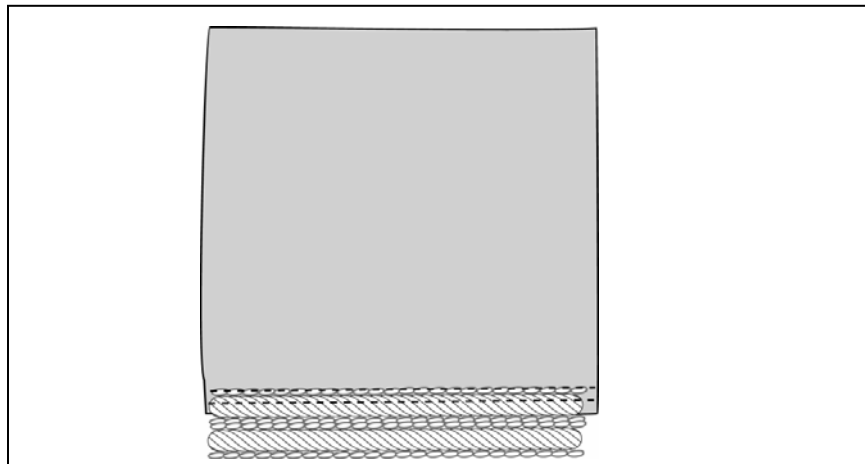

## Folded Edge Lace Insertion

*Use the Optional Flat Edge Lace Foot to sew lace to the underside of your fabric, while hemming the fabric on top at the same time.*

Huskylock Setting: **Cover Stitch Wide** on your Sewing Advisor

Fabric: Woven Light, such as batiste  
1” wide Flat Edging Lace

Thread: Regular cone thread

Tension: LN: 6 \_\_\_\_\_  
RN: 6 \_\_\_\_\_  
CL: 3 \_\_\_\_\_

Stitch Length: 3.5 as set by Sewing Advisor

Stitch Width: 7.0 as recommended by Sewing Advisor

Presser Foot: Optional Flat Edge Lace Foot

Fold fabric under ¼” and finger press. Insert folded fabric edge into the left fabric guide of foot, wrapping folded edge around guide. Insert lace into right guide of the foot, with wrong side of lace facing right side of fabric. The lace will lay on the underside of the fabric along the edge. Stitch lace and fabric together. The foot keeps both fabric and lace straight for perfect edges on lingerie or fine linens.

Place Sample Here:

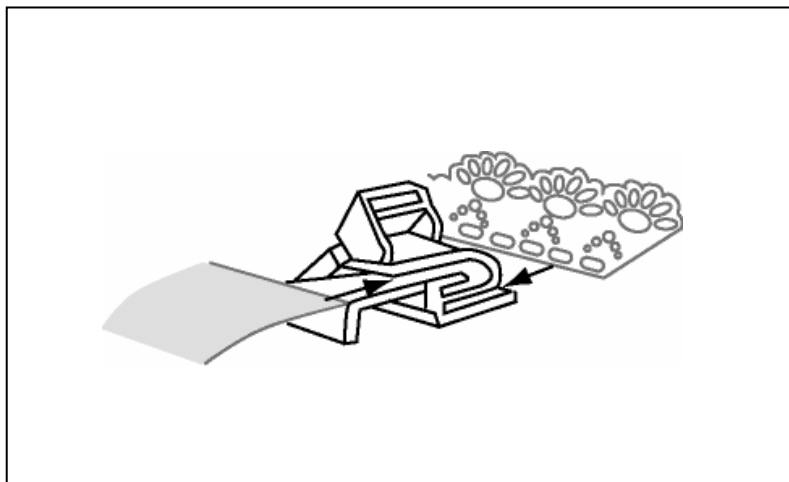

## Cover Stitch Pintucks with Cording

*Use the Optional Pintuck foot and guide to create beautiful, corded pintucks for your garment or project.*

Huskylock Setting: **Cover Stitch Narrow** on your Sewing Advisor

Fabric: Woven Light, such as batiste  
1/8" Cording

Thread: Regular cone thread

Tension: CN: 6 \_\_\_\_\_  
RN: 6 \_\_\_\_\_  
CL: 3 \_\_\_\_\_

Stitch Length: 3.5 as set by Sewing Advisor

Stitch Width: 7.0 as recommended by Sewing Advisor

Presser Foot: Optional Cover Stitch Cording/Piping Foot and Guide

Lay cord under cord guide, then snap cord guide into hole in front of needle plate "C". This eliminates having to thread the cord through the hole in the cord guide. Pull a 2" tail behind the foot and under the needles. Lay fabric on top of cord and sew over the top of the cord to create beautiful pin tucks.

*Hint: Use Optional Edge Guide to make even rows of pintucks on your project.*

**Place Sample Here:**

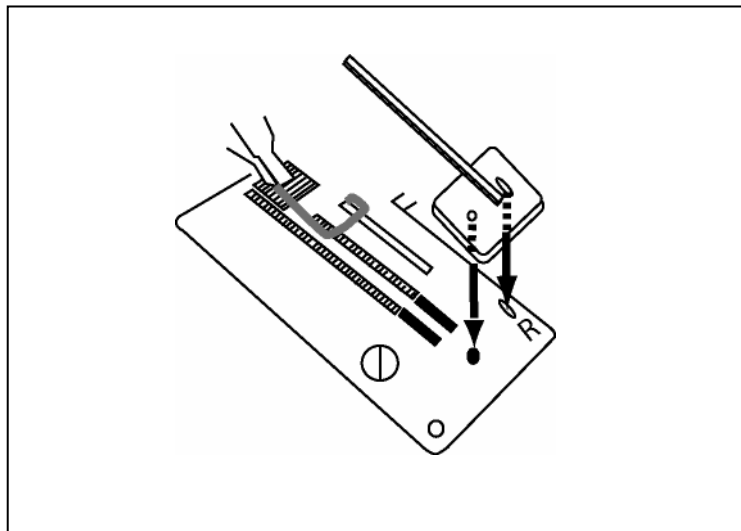

# Cover Stitch Cording

*Use the Optional Piping/Cording Foot with Cord Guide to sew 3mm cover stitch over cording. Perfect for window treatments when a shirred look is desired. Simply sew over cording or elastic cord, then pull from both ends to shirr.*

Huskylock Setting: **Cover Stitch Narrow** on your Sewing Advisor

Fabric: Woven Medium

Thread: Regular cone thread

Tension:      CN: 6      \_\_\_\_\_ }  
                  RN: 6      \_\_\_\_\_ } as recommended by Sewing Advisor  
                  CL: 3      \_\_\_\_\_ }

Stitch Length:      3.5 as set by Sewing Advisor

Stitch Width: 7 as recommended by Sewing Advisor

Presser Foot:      Optional Cover Stitch Piping/Cording Foot and Cord Guide

Snap on Piping/Cording Foot. Lay cord under cord guide, then snap cord guide into hole in front of needle plate “C”. This eliminates having to thread the cord through the hole in the cord guide. Pull a 2” tail behind the foot and under the needles. Lay fabric on top of cord and sew over the top of the cord.

For a decorative, raised seam look, use small cording and stitch randomly on your garment, or draw lines on your fabric and follow the lines.

To gather or shirr your fabric over the cord, use round elastic cord instead of the cording. Anchor one end of your cording and pull on the other end to draw up the gathers. You can use this technique with cording instead of elastic if you prefer.

Place Sample Here:

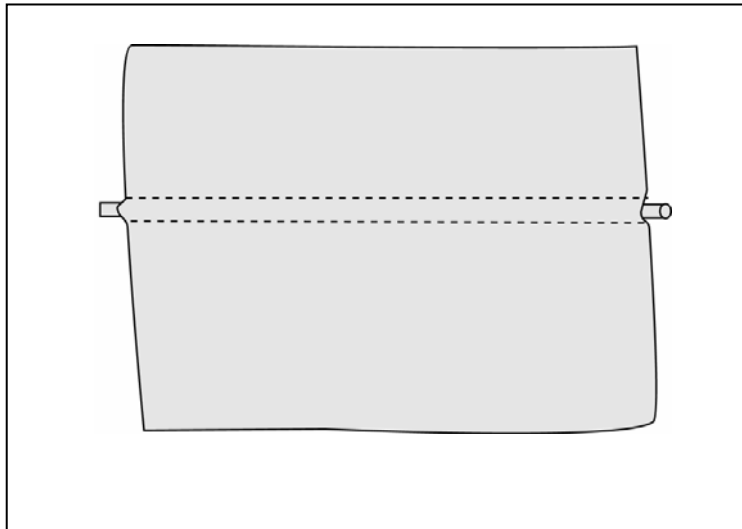

## Quarter Inch Piecing

*The 5-thread seam is great for speed quilt piecing and perfect for home dec. The chain stitch locks in the stitch, while giving a strong, flat seam.*

Huskylock Setting: **5 Thread Overlock** on your Sewing Advisor

Fabric: Woven Medium such as Calico

Thread: Regular cone thread

Tension: FN: 4 \_\_\_\_\_ }  
RN: 5 \_\_\_\_\_ } as recommended by Sewing Advisor  
UL: 3 \_\_\_\_\_ }  
LL: N \_\_\_\_\_ }  
CL: N \_\_\_\_\_ }

Stitch Length: 2.5 as set by Sewing Advisor

Stitch Width: 6.5

Presser Foot: "S"

Set stitch width at precisely 6.5 for a perfect 1/4' seam. Serge seam without cutting fabric.

*Hint: Use continuous piecing technique (kite-tailing) for time saving piecing instead of chaining off each piece individually. When you get to the end of one piece, slide the next piece up to the foot and continue serging until all pieces are joined in a "kite tail" fashion.*

Place Sample Here:

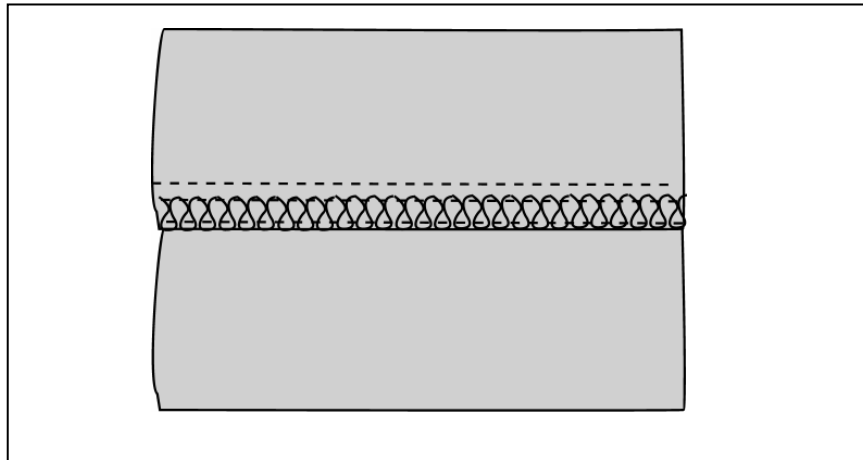

# Index

Bias Tape Binding Foot .....	24
Bias Tape Folder Foot.....	23
Blanket Stitch .....	14
Chainstitch Piping .....	19
Chainstitch Quilting .....	17
Clipped and Serged Seams .....	3
Corded Edges .....	12
Cording, Cover Stitch .....	26
Cover Stitch Bias Tape Binding Foot .....	24
Cover Stitch Bias Tape Folder Foot .....	23
Cover Stitch Cording.....	28
Cover Stitch Faggoting .....	20
Cover Stitch Hemming Foot .....	22
Cover Stitch Pintucks with Cording .....	27
Decorative Chainstitch Quilting .....	17
Decorative Cord.....	7
Decorative Flatlock .....	9
Decorative Mock Pintucks .....	18
Double Rolled Edge Piping .....	10
Elastic Button Loops .....	8
Fagoting, Cover Stitch .....	20
Flat Felled Seam, Mock .....	21
Flat Lace Application .....	25
Flatlock Lace Application, two thread.....	13
Flat Tube Strap.....	15
Folded Edge Lace Insertion .....	26
Hand-Look Quilting Stitch .....	16
Heirloom Lace Insertion .....	11
Hemming Foot, Cover Stitch .....	22
Mock Flat Felled Seam .....	21
Pintucks, Mock .....	18
Piping, Chainstitch .....	19
Quarter Inch Piecing .....	29
Quilting Chainstitch .....	17
Quilting Hand-Look Stitch .....	16
Serger Darts .....	4
Topstitched Ribbing .....	5
Two Step Binding .....	6
Two Thread Flatlock Lace Application .....	13