

## Desk pad with African Art Embroideries



### *Sewing Supplies*

- Husqvarna Viking Embroidery sewing machine
- 1 1/8 yd (1.10 m) brushed cotton fabric, 43" (110 cm) wide
- Thin cardboard, 1 piece 15 3/4" x 4 3/4" (40 x 12 cm), 1 piece 15 3/4" x 20 3/8" (40 x 52 cm)
- 2 2/3 yd (2.5 m) Narrow fold ready packaged Bias Binding
- Sulky 40 wt. Embroidery thread
- Sewing thread in matching color to the binding
- Husqvarna Viking Stick On stabilizer
- Spray glue
- Husqvarna Viking card/disk/d-Card 37, African Arts

### CUT

In fabric:

2 pieces 19 5/8" x 29 5/8" (50 x 75 cm).

### EMBROIDERIES

Mark out the center point for the embroidery in the lower right corner 4" (10 cm) from both edges. Hoop Stick On stabilizer in standard 100 x 100 hoop with the paper side up. Score the paper with a pin and pull paper off. Stick the fabric to the sticky surface. Embroider design 13.

Mark two 10" (25.5 cm) long lines with a pictogram pen, starting 3/8" (1 cm) from the tips of the corner design, The end of the line is the center point for the arrows, design 23. Embroider the designs in the same way as you did with the corner design, with Stick On stabilizer in the hoop. Illustration A.

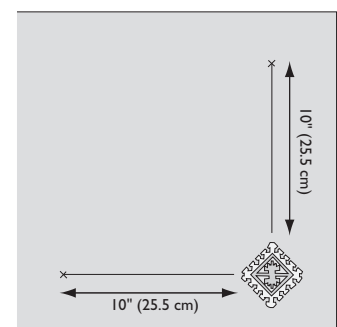



Illustration A.

Snap on presser foot B. Use embroidery thread on top and bobbin thread in the same color as the shaft of the embroidered arrows. Select a satin stitch , (Designer I: C22, Designer II, QD: A1 22) Adjust length to 0.2, width 6.0. Start stitching from the holder of the arrows and up along the drawn line. Stop stitching 2.5 cm from the end of the marked line. Select a tapered satin stitch , (Designer I: C1, Designer II, QD: A1 01). Mirror image end to end. (If you do not have a Designer, adjust stitch width gradually in the end of the line to make the tapered end. Illustration B.

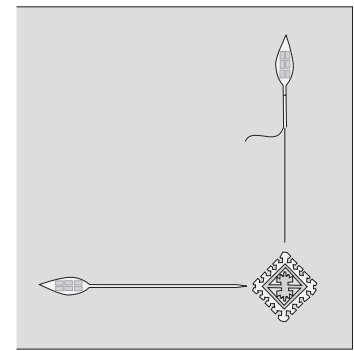

Illustration B.

Pin the pieces wrong sides together. Place the cardboard pieces on top with 4-5 mm space. Mark with a pictogram pen around both pieces and a vertical line between, and remove them from the fabric. Illustration C.

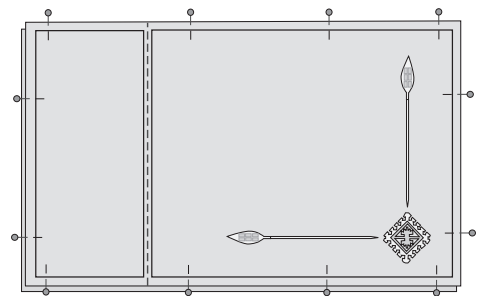

Illustration C.

Snap on presser foot A. Select straight stitch. Stitch following the markings on three sides of the deskpad leaving one short side open. Trim the fabric edges to 1/4" (6 mm) outside the stitching.

Select a narrow zigzag stitch, length 1.0, width 1.5. Fold the ready made bias binding around the stitched edges of the deskpad and bias bind the three sides. Illustration D.

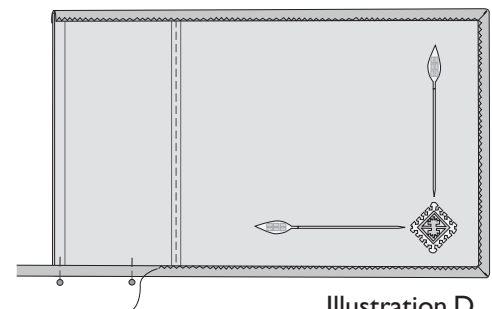

Illustration D.

Insert the large cardboard piece. Select straight stitch again and straight stitch in the vertical marked line. Insert the narrow cardboard piece. Straight stitch the open side and trim the edge seam allowance to 1/4" (6 mm). Select the narrow zigzag stitch, length 1.0, width 1.5 again. Bias bind the last edge. Illustration E.

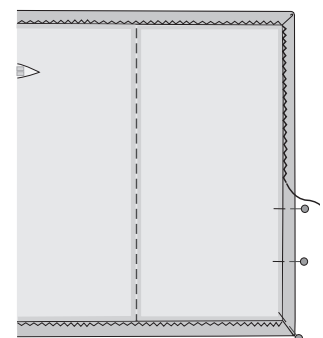

Illustration E.



 **Husqvarna**

**VIKING**