

Fab-U-Motion with Stitch Regulator by Quilters Cruise Control

Compatible Husqvarna Viking Models:

Husqvarna Viking Freesia 350,400, 400-N and 400 LE, 415, 425

Husqvarna Viking Lily 535, 540, 545, 550, 555

Husqvarna Viking Rose 600, 605

Husqvarna Viking Platinum 730, 750, 770

Husqvarna Viking Scandinavia 200, 300 &400

Husqvarna Viking Sapphire 830, 850 and 870

Husqvarna Viking Designer Series, Designer SE, Designer SE Limited Edition, Designer I, Designer I USB, Designer II, Quilt Designer

How to set for free motion:

1. Lower the feed teeth:

Slide the lever to the left toward the -.

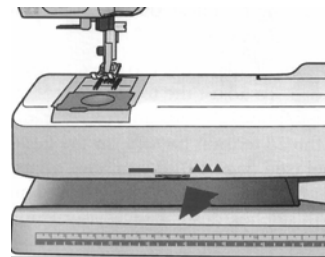

2. Lower the Presser Foot Pressure to the - - - . The Presser Foot Pressure is located on the front of the machine, upper left. (for Sapphire Machines, touch SET, then select Free Motion Floating or Free Motion Spring Action depending on the foot you are using)

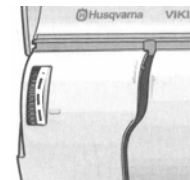

3. Insert a Universal needle, Quilting needle, Topstitch needle or Denim Needle. Choose the size and type for the fabric and project being sewn. For great needle advice, consult the Needle Genius by Thread Tek #140002412.

4. Attach a free motion foot. It can be any of the following for the above models:

- Open Toe Stippling Foot #412 61 34-45
- Free Motion Guide Foot #412 61 37-45
- Darning/Quilting Foot #412 54 17-45

5. Start with the tension at normal. Stitch on a scrap, the same as your project. If the top thread is pulling to the back as shown, raise the upper thread tension to a higher number. Continue to increase the tension to a higher number until stitch is balanced.



Poor Tension
(wrong side)



Good Tension
(wrong side)

Husqvarna Viking Designer I

1. Be sure your Designer I is updated to the current software version. Go to www.husqvarnaviking.com, USA, Designer Updates to check for the most current version.

2. Lower the feed teeth: Slide the lever to the left toward the — as shown.

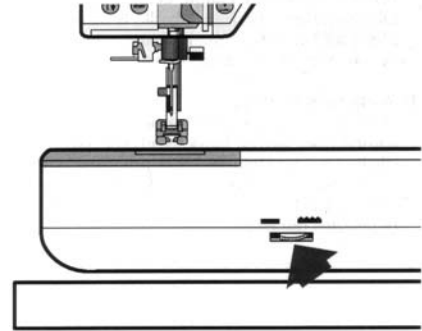

3. Select V Menu, Stitch V1 for Free Motion stitching where the top thread should pull to the back as in monogramming.

OR

Select A2, and activate Free Motion in the SET menu for balanced tension.

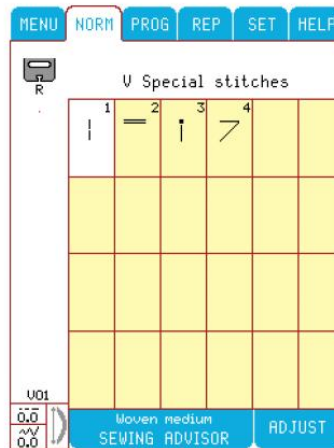

Or

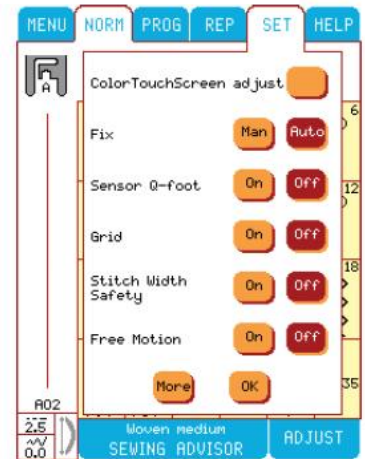

4. Select Needle Stop Down.

5. Insert a Universal needle, Quilting needle, Topstitch needle or Denim Needle. Choose the size and type for the fabric and project being sewn. For great needle advice, consult the Needle Genius by Thread Tek #140002412.

6. Attach a free motion foot choosing any from the list below:

Open Toe Free Motion Spring Foot #413037645 (Set for Sensor Q Foot in the SET menu)

Clear Open Toe Free-Motion Foot #412 86 06-45

Open Toe Stippling Foot #412 80 10-45

Free Motion Guide Foot #412 57 64-45

Darning/Quilting Foot "R" Foot

Sensor Q foot #412 59 75-45 (Set for Sensor Q Foot in the SET menu)

6. Start with the tension at normal. Stitch on a scrap, the same as your project. If the top thread is pulling to the back as shown, raise the upper thread tension to a higher number. Continue to raise the tension until the stitch is balanced.



Poor Tension
(wrong side)



Good Tension
(wrong side)

Husqvarna Viking Quilt Designer, Designer II, Quilt Designer II

1. Be sure your machine is updated to the most current version. Go to www.husqvarnaviking.com, USA, Designer Updates to check for the most current version.
2. Lower the feed teeth: Slide the lever to the left toward the — as shown.

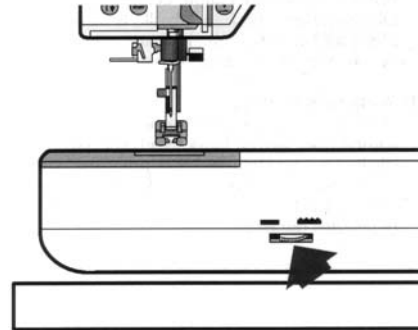

3. Select V Menu, Stitch V1 for Free Motion stitching where the top thread should pull to the back as in monogramming.



4. Select Needle Stop Down.
5. Insert a Universal needle, Quilting needle, Topstitch needle or Denim Needle. Choose the size and type for the fabric and project being sewn. For great needle advice, consult the Needle Genius by Thread Tek #140002412.
6. Attach a free motion foot choosing any from the list below:
 - Open Toe Free Motion Spring Foot #413037645 (Set for Sensor Q Foot in the SET menu)
 - Clear Open Toe Free-Motion Foot #412 86 06-45
 - Open Toe Stippling Foot #412 80 10-45
 - Free Motion Guide Foot #412 57 64-45
 - Darning/Quilting Foot “R” Foot
 - Sensor Q foot #412 59 75-45 (Set for Sensor Q Foot in the SET menu)

7. Start with the tension at normal. Stitch on a scrap, the same as your project. If the top thread is pulling to the back as shown, raise the upper thread tension to a higher number. Continue to raise the tension until the stitch is balanced.



Poor Tension
(wrong side)



Good Tension
(wrong side)

Husqvarna Viking Designer SE and Designer SE Limited Edition:

1. Be sure your Designer SE is updated to the most current version of internal software. Go to www.husqvarnaviking.com, USA, Designer Updates to check for the most current version.
2. The Feed Teeth will lower automatically when selecting Free Motion Stitching in the SET menu or when selecting a stitch from the V menu. Select V Menu, Stitch V1 for Free Motion.
3. Select Needle Stop Down.

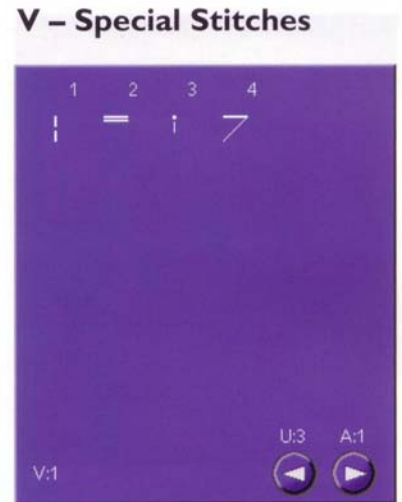

4. Insert a Quilting needle, Topstitch needle or Denim Needle. Choose the size and type for the fabric and project being sewn.
5. Attach a free motion foot choosing any from the list below:
 - Open Toe Free Motion Spring Foot #413037645 (Set for Sensor Q Foot in the SET menu)
 - Clear Open Toe Free-Motion Foot #412 86 06-45
 - Open Toe Stippling Foot #412 80 10-45
 - Free Motion Guide Foot #412 57 64-45
 - Darning/Quilting Foot "R" Foot
 - Sensor Q foot #412 59 75-45 (Set for Sensor Q Foot in the SET menu)
6. Start with the tension at normal. Stitch on a scrap, the same as your project. If the top thread is pulling to the back as shown, raise the upper thread tension to a higher number. Continue to raise the tension until the stitch is balanced.



Poor Tension
(wrong side)

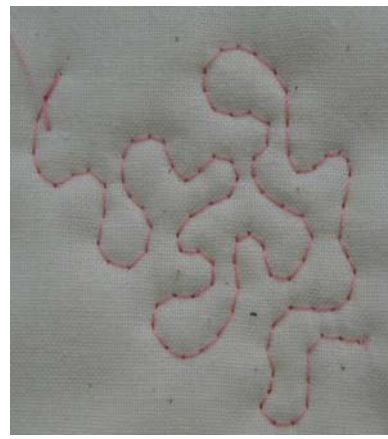

Good Tension
(wrong side)

Getting Started with your Fab-U-Motion with Stitch Regulator by Quilters Cruise Control

Set up for Free Motion following the previous instructions here and/or in your User's Guide.

Prepare:

1. Make a 20" x 20" fabric and batting sandwich to practice on by placing a 20" x 20" piece of cotton batting between two 20" x 20" squares of muslin. This is good for practicing free motion quilting.
2. Use a 20" x 20" piece of home dec weight fabric or denim to practice free motion embroidery. Depending on the weight of your fabric, you may need Tear-A-Way stabilizer underneath the fabric.

Hints:

- Set needle to stop in the down position.
- Move the Fab-U-Motion Textured Surface, not the fabric.
- Use your left foot on the Foot on/off switch. It is an on/off switch, not a speed control. Most people find their left foot "doesn't know how to sew".
- Always take a few stitches in place when beginning to sew, until your machine reaches speed.

Free Motion Quilting Basics:

1. Insert a Quilting needle, Topstitch needle or Denim Needle. Choose the size and type for the fabric and project being sewn. Needle type and size are chosen by the fabric and threads being used. Go to www.husqvarnaviking.com, USA, Education, Tips and Hints for a needle tip sheet. It tells about the different types and sizes of needles and when to use them.
2. Thread with the same thread top and bobbin. This is usually cotton thread when quilting, either 50 wt. cotton sewing thread or Sulky 30 wt. Cotton or Sulky Blendable thread.
3. Select a balanced tension stitch as indicated for your model.
4. Attach your Fab-U-Motion with Stitch Regulator according to the instructions that were included with it.
5. Set your machine speed one notch slower if you have this option.
6. Begin by setting the stitch length size on the Fab-U-Motion "Brain" to the smallest setting, by turning the wheel all the way to the left, as shown. Place the fabric onto the textured surface of the Fab-U-Motion.



Wheel

7. Stitch a few stitches in place, then begin to move the Fab-U-Motion with Stitch Regulator Textured Surface. Move the surface back and forth as shown, first left to right, then up and down.
8. Adjust the stitch to the longest setting, all the way to the right, and repeat your stitching. You should see a difference in the length of the stitches.

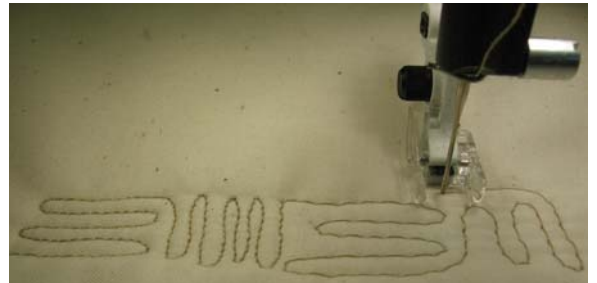

9. Next, move the stitch length wheel to the middle. You will feel a definite “click” at the medium stitch length that is used by many for machine quilting. Stitch some stippling. Stippling is a traditional quilting pattern that stitches randomly in a curvy motion over the quilt, without crossing previous stitching.



10. Remove the fabric from the machine, and check the tension. You should have a good stitch top and bottom as shown. If you don't have a balanced stitch on the back, increase your upper tension until the stitch is balanced.



Poor tension
(wrong side)



Good Tension
(wrong side)

11. When you have filled up an area and need to move the fabric to a new section, be sure your needle is down, then reach underneath the fabric and move the Textured Surface of the Fab-U-Motion. If you started on the left top of your fabric, you then want to move so that the needle is now located in the upper right corner of the opening. That way you can continue stitching to the left, and down. Remember, move the textured surface of the Fab-U-Motion, not the fabric.

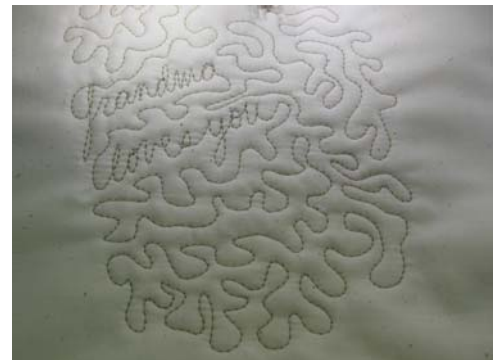

12. Continue stitching, with your stippling, and other designs. Try writing your name. It is lots of fun to stitch a secret message into a quilt for kids!

13. As you are quilting, you will see that your smooth movements are important for even stitching and smooth curves. Keep in mind that you that you are moving the Fab-U-Motion surface, not the fabric. Continue stitching until you have filled your fabric. You are then ready to move on!

Visit the website, www.husqvarnaviking.com, and click on Accessories, and Fab-U-Motion for quilting projects and creative embellishment ideas for the Fab-U-Motion with Stitch Regulator.

Free Motion Stitching Basics:

1. Thread your machine with rayon 40 wt. embroidery thread on top and bobbin thread in the bobbin. On your home dec or denim fabric, select V1 on Designer Models. This will result in the top thread being pulled to the back of the fabric, as in embroidery. On other models, lower your top tension one or two numbers to bring the top thread to the back.

2. Place your home dec fabric or denim, on the Fab-U-Motion with Stitch Regulator. You may find that some projects are small and hard to hold on to. Try clipping them to the textured surface of the Fab-U-Motion with Binder Clips as shown. They are available in office supply stores.



3. Begin again, and place a patterned sheer fabric scarf type on top of your denim or home dec fabric. Follow the pattern in the fabric and stitch around a design as shown.

4. Trim about 1/4" away from the design and brush with a Chenille Brush. For projects using this technique, go to www.husqvarnaviking.com, USA, and click on Accessories, and the Fab-U-Motion.



Satin Stitch Free Motion Embroidery with the Fab-U-Motion:

5. Begin stitching as before, to get the feel on a different type of fabric. Traditional machine embroidery is often done with a zig zag stitch, select V2 on Designer Models zig zag stitch on other models.. Because you have to move the fabric very slowly to form the satin stitch, unplug the Fab-U-Motion with Stitch Regulator and plug in your regular foot control. You are now taking advantage of the ease of free motion using the Fab-U-Motion surface, but you are now regulating the length of the stitch yourself. Practice a bit to create a nice satin stitch. If you have lots of space between the stitches, move the Fab-U-Motion textured surface slower.

