

Husqvarna Viking Chenille Foot

412 9752-45

1, 2, 3, 4, 5, 6, 7

- Purchase Chenille It Blooming Bias 100% cotton bias strips available in a variety of colors in 5/8" width and 3/8" width.
- Easily embellish clothing, home dec items and quilts

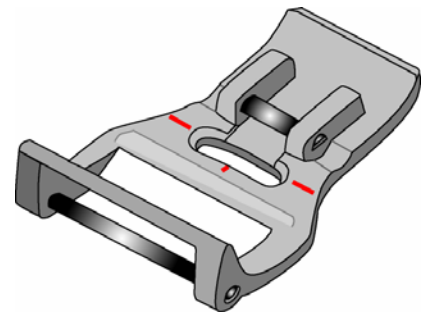

1. Thread your Husqvarna Viking sewing machine with quality polyester sewing thread top and bobbin.
2. Select a straight stitch, stitch length 1.5. A tip from Kerstin Widell from the Research and Development Department at Husqvarna Viking in Sweden is to select the Husqvarna Viking lightening stitch for a stronger stitch.
3. 5/8" width Blooming Bias: Place one to three layers of chenille strips into the Husqvarna Viking Chenille Accessory Presser Foot sliding the strips between the front guides then under the presser foot. It may be easier to feed the strips into the foot before snapping onto your Husqvarna Viking.
4. 3/8" width Blooming Bias: Place Blooming Bias strips between the front guides then into the hole where the needle goes through the foot and back and under the foot.
5. Combine widths: Place 5/8" strip into front guide with a 3/8" strip on top and into needle hole.
6. Stitch the Blooming Bias in place. The Chenille Foot will guide the strips.
7. Machine wash and dry on regular cycle or dampen with water and brush with stiff chenille brush.

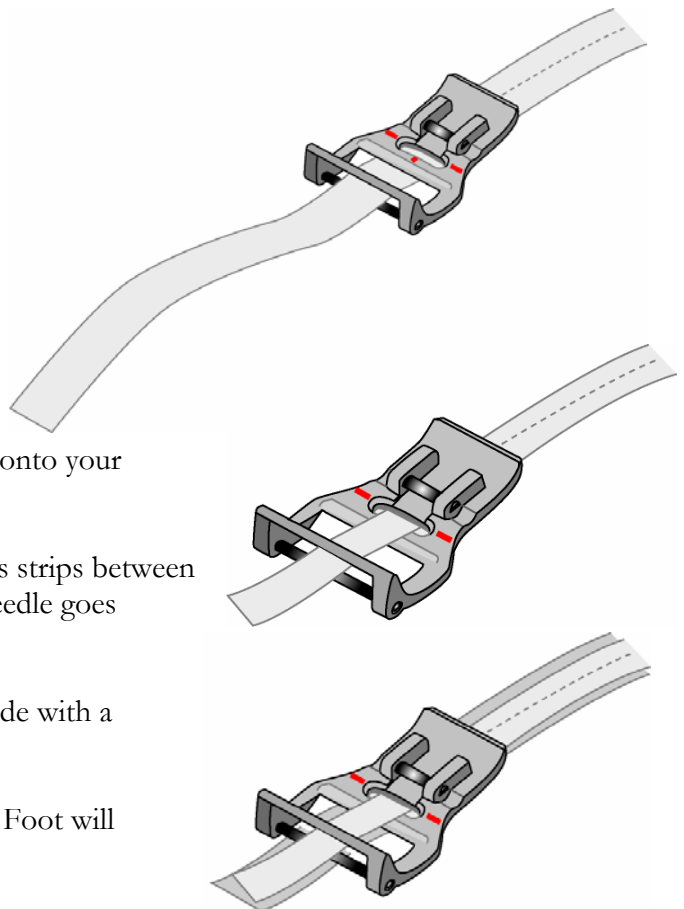

For Chenille "Binding": Stitch Blooming Bias around the edges of a garment. (Finish edges first with Huskylock four thread or sewing machine 3 step zigzag). At corners simply stitch off the edge, cut bias and start at edge to continue around the corner.

Add chenille "buttons" and details": Stitch a square of layered Blooming Bias in place with a bar tack. Brush or wash.